

HP 2533t Mobile Thin Client Maintenance and Service Guide



© Copyright 2008 Hewlett-Packard
Development Company, L.P.

Bluetooth is a trademark owned by its proprietor and used by Hewlett-Packard Company under license. Microsoft, Windows, and Windows Vista are U.S. registered trademarks of Microsoft Corporation. SD Logo is a trademark of its proprietor.

The information contained herein is subject to change without notice. The only warranties for HP products and services are set forth in the express warranty statements accompanying such products and services. Nothing herein should be construed as constituting an additional warranty. HP shall not be liable for technical or editorial errors or omissions contained herein.

First Edition: May 2008

Document Part Number: 462925-001

Safety warning notice

-
- ⚠ **WARNING!** To reduce the possibility of heat-related injuries or of overheating the computer, do not place the computer directly on your lap or obstruct the computer air vents. Use the computer only on a hard, flat surface. Do not allow another hard surface, such as an adjoining optional printer, or a soft surface, such as pillows or rugs or clothing, to block airflow. Also, do not allow the AC adapter to contact the skin or a soft surface, such as pillows or rugs or clothing, during operation. The computer and the AC adapter comply with the user-accessible surface temperature limits defined by the International Standard for Safety of Information Technology Equipment (IEC 60950).
-

Table of contents

1 Product description

2 External component identification

Top components	4
Display	4
TouchPad	5
Buttons	6
Keys	7
Lights	8
Front components	10
Right-side components	11
Left-side components	12
Rear components	13
Bottom components	14

3 Illustrated parts catalog

Serial number location	15
Computer major components	16
Plastics Kit	19
Cable Kit	20
Miscellaneous parts	20
Sequential part number listing	21

4 Removal and replacement procedures

Preliminary replacement requirements	23
Tools required	23
Service considerations	23
Plastic parts	23
Cables and connectors	24
Drive handling	24
Grounding guidelines	25
Electrostatic discharge damage	25
Packaging and transporting guidelines	26

Workstation guidelines	26
Equipment guidelines	27
Unknown user password	28
Component replacement procedures	29
Serial number	29
Computer feet	30
Battery	30
Memory module	32
WLAN module	34
Flash drive	36
Optical drive	38
Switch cover and keyboard	40
USB board and optical drive bezel	44
RTC battery	46
Display assembly	47
Top cover	52
LED board	55
Speaker	56
System board	57
PC Card assembly	59
Modem module	61
Heat sink	63

5 Computer Setup

Starting Computer Setup	65
Using Computer Setup	66
Navigating and selecting in Computer Setup	66
Restoring factory settings in Computer Setup	66
Computer Setup menus	67
File menu	67
Security menu	67
Diagnostics menu	67
System Configuration menu	68

6 Specifications

Computer specifications	69
12.1-inch, WXGA display specifications	70
8X Max DVD-ROM Drive specifications	71
System DMA specifications	72
System interrupt specifications	73
System I/O address specifications	74
System memory map specifications	76

7 Screw listing

Phillips PM2.5×6.0 captive screw	78
Phillips PM2.0×4.0 screw	79
Torx T8M2.0×5.0 screw	82
Torx T8M2.5×6.0 screw	84
Phillips PM2.5×11.0 captive screw	87
Phillips PM2.5×4.0 screw	88
Phillips PM2.0×6.0 screw	89
Phillips PM2.0×5.0 screw	90
Torx T8M2.0×10.0 captive screw	91

8 Connector pin assignments

Audio-out (headphone)	92
Audio-in (microphone)	92
External monitor	93
RJ-11 (modem)	94
RJ-45 (network)	95
Universal Serial Bus	95

9 Power cord set requirements

Requirements for all countries and regions	96
Requirements for specific countries and regions	97

10 Recycling

Battery	98
Display	98

Index	104
--------------------	------------

1 Product description

Category	Description
Product Name	HP 2533t Mobile Thin Client
Processors	Via C7-M Ultra-Low Voltage (ULV) 1.00-GHz, 128-KB L2 cache, 400-MHz front side bus (FSB)
Chipset	Northbridge: Via CN896 Southbridge: Via VT8237S
Graphics	Via Chrome 9 Universal Memory Architecture (UMA) graphics subsystem integrated with 128-MB shared system memory
Panels	12.1-inch WXGA display assembly (1280 × 800) with Antiglare, includes 2 wireless local area network (WLAN) antennae, and supports privacy filter
Memory	One customer-accessible/upgradable memory module slot Supports up to 2 GB of system RAM PC2-5300, 667-MHz, DDR2 Supports the following configurations: <ul style="list-style-type: none">• 2048-MB total system memory (2048 × 1)• 1024-MB total system memory (1024 × 1)
Primary storage device	1-GB flash drive Customer-accessible Parallel ATA (PATA)
Optical drives	Fixed (removal of 2 screws required) Customer-accessible Serial ATA (SATA) 9.5-mm tray load Supports the following drive options: <ul style="list-style-type: none">• DVD-ROM Drive• No optical drive with optical drive space saver
Diskette drive	Supports external USB diskette drive only Supports boot from external USB diskette drive Supports 3-mode diskette drive

Category	Description
Audio	HD audio - ADI1984HDA
	Integrated single speaker, no speaker branding
	Integrated single microphone
Modem	56K V.92 1.5-inch data/fax modem
Ethernet	Integrated Broadcom 5787M 10/100/1000 (local access network (LAN))
	S5 wake on LAN on AC power
	NIC power down technology
Wireless	Integrated WLAN options by way of wireless module:
	Support for 2 dual-band 2.4-/5.0-GHz WLAN antennae built into display assembly
	Support for no-WLAN option
	Support for Broadcom 802.11a/b/g WLAN format
External media card	One Type I/II PC Card slot, 16-bit PCMCIA and 32-bit Cardbus
	SD/MMC Card Reader supporting Secure Digital (SD) Memory Card and MultiMediaCard (MMC)
Ports	Audio-in (stereo microphone)
	Audio-out (stereo headphone)
	Docking
	RJ-11 (modem)
	RJ-45 (Ethernet, includes link and activity lights)
	USB (2 with optical drive, 3 without optical drive)
	VGA (Dsub 15-pin) supporting 1600 × 1200 external resolution at 75-GHz (hot plug/unplug with auto-detect)
	3-pin AC power via the HP Smart Adapter
Docking	HP 2400/2500 Series Docking Station (TV-out connector does not work)
Keyboard/pointing devices	4.21-inch × 10.71-inch keyboard with embedded numeric keypad
	Pointing stick with 2 pointing stick buttons
	TouchPad with 2 TouchPad buttons and vertical scrolling zone
	Spill-resistant keyboard
	Windows Vista® Start button
	Durable key caps
Power requirements	65-W AC adapter with localized cable plug support (2-wire plug with ground pin, supports 3-pin DC connector)
	9-cell, 83.0-Wh Li-ion battery with fuel gauge
	6-cell, 55.0-Wh Li-ion battery with fuel gauge
	3-cell, 31.0-Wh Li-ion battery with fuel gauge

Category	Description
Security	Supports Kensington security sock
	Optional removable active smart card reader, occupies the single PC Card slot
Operating system	Preinstalled:
	Windows® XP Embedded (XPe) in French, Japanese, Korean, Simplified Chinese, Spanish, Traditional Chinese, and U.S. English
Serviceability	End-user replaceable parts:
	AC adapter
	Battery (system)
	Flash drive
	Memory module
	Optical drive
	RTC battery
WLAN module	

2 External component identification

Top components

Display



Item	Component	Function
(1)	Wireless antennae (2)	<p>Send and receive signals from one or more wireless devices. These antennae are not visible from the outside of the computer.</p> <p>NOTE: For optimal transmission, keep the areas immediately around the antennae free from obstructions.</p> <p>NOTE: To see wireless regulatory notices, refer to the section of the Regulatory, Safety and Environmental Notices that applies to your country or region. These notices are located in the printed <i>Getting Started guide</i>.</p>
(2)	Internal microphone	Records sound.

TouchPad



Item	Component	Function
(1)	Pointing stick*	Moves the pointer and selects or activates items on the screen.
(2)	Left pointing stick button*	Functions like the left button on an external mouse.
(3)	TouchPad*	Moves the pointer and selects or activates items on the screen.
(4)	Left TouchPad button*	Functions like the left button on an external mouse.
(5)	Right pointing stick button*	Functions like the right button on an external mouse.
(6)	TouchPad scroll zone	Scrolls up or down.
(7)	Right TouchPad button*	Functions like the right button on an external mouse.

*This table describes factory settings. To view or change pointing device preferences, select **Start > Control Panel > Printers and Other Hardware > Mouse**.

Buttons



Item	Component	Function
(1)	Power button	<ul style="list-style-type: none">• When the computer is off, press the button to turn on the computer.• When the computer is on, press the button to turn off the computer.• When the computer is in Standby, press the button briefly to exit Standby.
(2)	Info button	Launches Info Center.
(3)	Wireless button	Turns the wireless feature on or off, but does not establish a wireless connection. NOTE: A wireless network must be set up in order to establish a wireless connection.
(4)	Presentation button	Opens the Presentation Options window, where you can start a frequently used presentation, file, program, or Web site. You can also adjust display settings for optimum viewing.
(5)	TouchPad on/off button	Turns the TouchPad on or off.
(6)	Volume mute button	Mutes and restores computer sound.
(7)	Volume scroll zone	Adjusts speaker volume. Slide your finger to the left to decrease volume and to the right to increase volume.

Keys

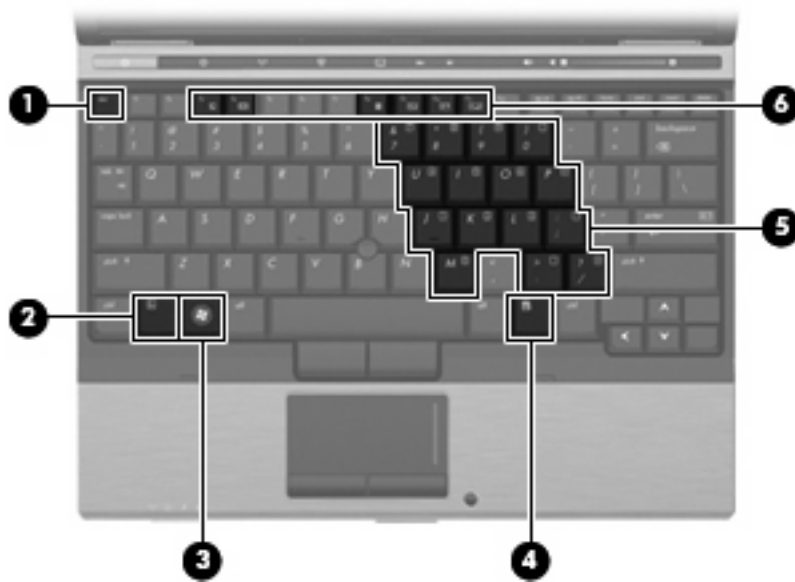

Item	Component	Function
(1)	esc key	Displays system information when pressed in combination with the fn key.
(2)	fn key	Executes frequently used system functions when pressed in combination with a function key or the esc key.
(3)	Windows logo key	Displays the Windows Start menu.
(4)	Windows applications key	Displays a shortcut menu for items beneath the pointer.
(5)	Embedded numeric keypad keys	Can be used like the keys on an external numeric keypad.
(6)	Function keys	Execute frequently used system functions when pressed in combination with the fn key.

Lights



Item	Component	Function
(1)	Wireless lights* (2)	<ul style="list-style-type: none"> Blue: An integrated wireless device, such as a wireless local area network (WLAN) device, is on. Amber: All wireless devices are off.
(2)	Power lights† (2)	<ul style="list-style-type: none"> On: The computer is on. Blinking: The computer is in Standby. Off: The computer is off.
(3)	Battery light	<ul style="list-style-type: none"> Amber: A battery is charging. Turquoise: A battery is close to full charge capacity. Blinking amber: A battery that is the only available power source has reached a low battery level. When the battery reaches a critical battery level, the battery light begins blinking rapidly. Off: If the computer is plugged into an external power source, the light turns off when all batteries in the computer are fully charged. If the computer is not plugged into an external power source, the light stays off until the battery reaches a low battery level.
(4)	Drive light	Blinking: The flash drive or optional optical drive is being accessed.
(5)	TouchPad on/off light	<ul style="list-style-type: none"> Turquoise: TouchPad is on. Amber: TouchPad is off.
(6)	Caps lock light	On: Caps lock is on.
(7)	Num lock light	On: Num lock is on.

Item	Component	Function
(8)	Volume mute light	<ul style="list-style-type: none">• Turquoise: Computer sound is on.• Amber: Computer sound is off.

*The 2 wireless lights display the same information. The light on the wireless button is visible only when the computer is open. The wireless light on the front of the computer is visible whether the computer is open or closed.

†The 2 power lights display the same information. The light on the power button is visible only when the computer is open. The power light on the front of the computer is visible whether the computer is open or closed.

Front components

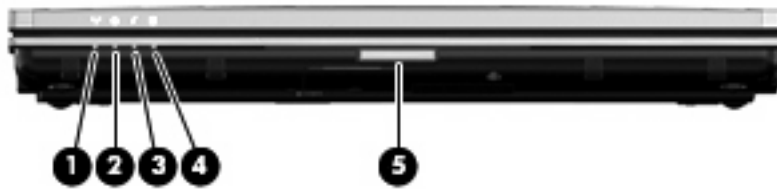

Item	Component	Function
(1)	Wireless light	<ul style="list-style-type: none">• Blue: An integrated wireless device, such as a wireless local area network (WLAN) device, is on.• Amber: All wireless devices are off.
(2)	Power light	<ul style="list-style-type: none">• On: The computer is on.• Blinking: The computer is in Standby.• Off: The computer is off.
(3)	Battery light	<ul style="list-style-type: none">• Amber: A battery is charging.• Turquoise: A battery is close to full charge capacity.• Blinking amber: A battery that is the only available power source has reached a low battery level. When the battery reaches a critical battery level, the battery light begins blinking rapidly.• Off: If the computer is plugged into an external power source, the light turns off when all batteries in the computer are fully charged. If the computer is not plugged into an external power source, the light stays off until the battery reaches a low battery level.
(4)	Drive light	Blinking: The flash drive or optional optical drive is being accessed.
(5)	Display release latch	Opens the computer.

Right-side components

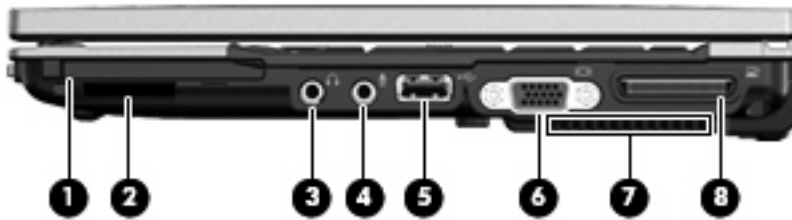

Item	Component	Function
(1)	PC Card slot*	Supports optional Type I and Type II 32-bit (CardBus) or 16-bit PC Cards.
(2)	SD Card Reader*	Supports the Secure Digital (SD) Memory Card and MultiMediaCard (MMC) optional digital card formats.
(3)	Audio-out (headphone) jack	Produces sound when connected to optional powered stereo speakers, headphones, ear buds, a headset, or television audio.
(4)	Audio-in (microphone) jack	Connects an optional computer headset microphone, stereo array microphone, or monaural microphone.
(5)	USB port†	Connects an optional USB device.
(6)	External monitor port	Connects an external VGA monitor or projector.
(7)	Vent	Enables airflow to cool internal components.
(8)	Docking connector	Connects an optional docking device.

*To view the status of the PC Card Slot and SD Card Reader, go to Computer Setup (f10).

†To view the status of the USB ports, use the USB Storage Options utility. Refer to the “Securing USB ports” section in the *Administrator’s Guide* for additional information.

Left-side components

 **NOTE:** Refer to the illustration that most closely matches your computer.

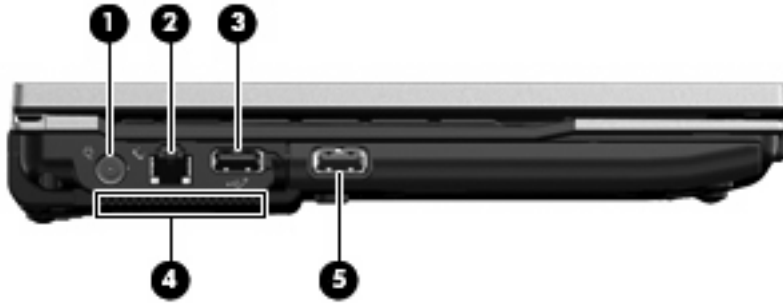

Item	Component	Function
(1)	Power connector	Connects an AC adapter.
(2)	RJ-11 (modem) jack	Connects a modem cable.
(3)	Powered USB port*	Provides power to an external device if used with a powered USB cable.
(4)	Vent	Enables airflow to cool internal components.
(5)	USB port*	Connects an optional USB device.

*To view the status of the USB ports, use the USB Storage Options utility. Refer to the “Securing USB ports” section in the *Administrator’s Guide* for additional information.

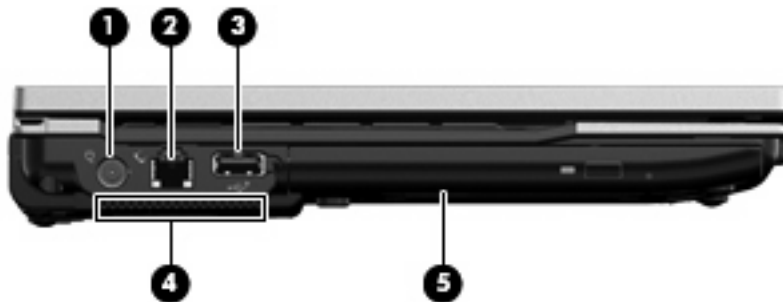

Item	Component	Function
(1)	Power connector	Connects an AC adapter.
(2)	RJ-11 (modem) jack	Connects a modem cable.
(3)	Powered USB port*	Provides power to an external device if used with a powered USB cable.
(4)	Vent	Enables airflow to cool internal components.
(5)	Optical drive (select models only)	Reads an optical disc.

*To view the status of the USB ports, use the USB Storage Options utility. Refer to the “Securing USB ports” section in the *Administrator’s Guide* for additional information.

Rear components



Item	Component	Function
(1)	RJ-45 (network) jack	Connects a network cable.
(2)	Security cable slot	Attaches an optional security cable to the computer.

NOTE: The security cable is designed to act as a deterrent, but it may not prevent the computer from being mishandled or stolen.

Bottom components

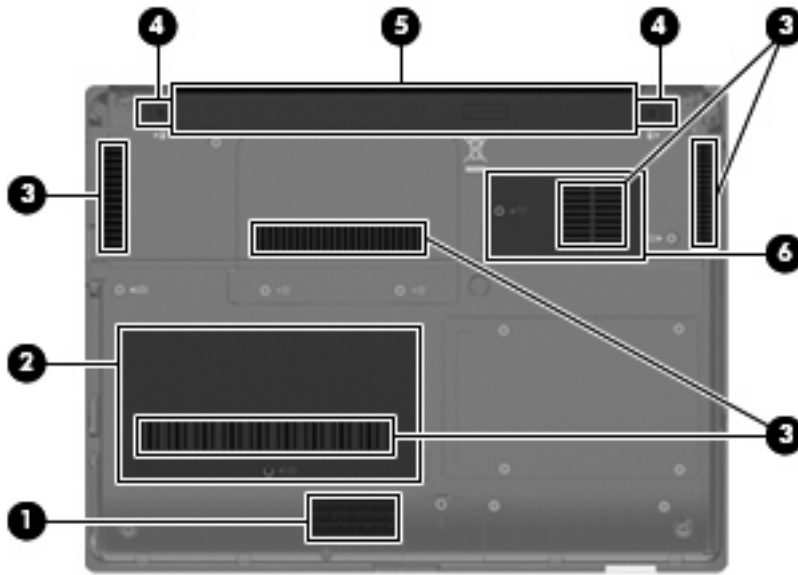

Item	Component	Function
(1)	Speaker	Produces sound.
(2)	Memory module compartment	Contains a memory module slot and a WLAN module slot. CAUTION: To prevent an unresponsive system, replace the wireless module only with a wireless module authorized for use in the computer by the governmental agency that regulates wireless devices in your country or region. If you replace the module and then receive a warning message, remove the module to restore computer functionality.
(3)	Vents (5)	Enable airflow to cool internal components.
(4)	Battery release latches (2)	Release the battery from the battery bay.
(5)	Battery bay	Holds the battery.
(6)	Flash drive bay	Holds the flash drive.

3 Illustrated parts catalog

Serial number location

When ordering parts or requesting information, provide the computer serial number and model number located on the bottom of the computer.

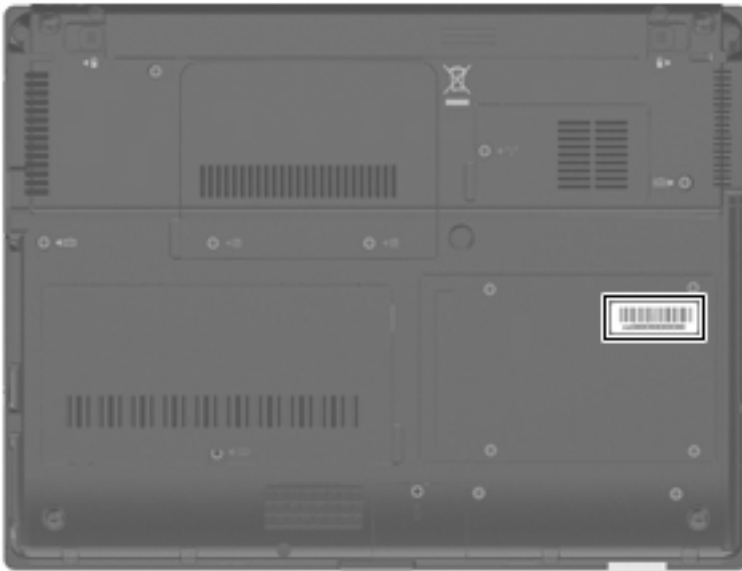

Computer major components

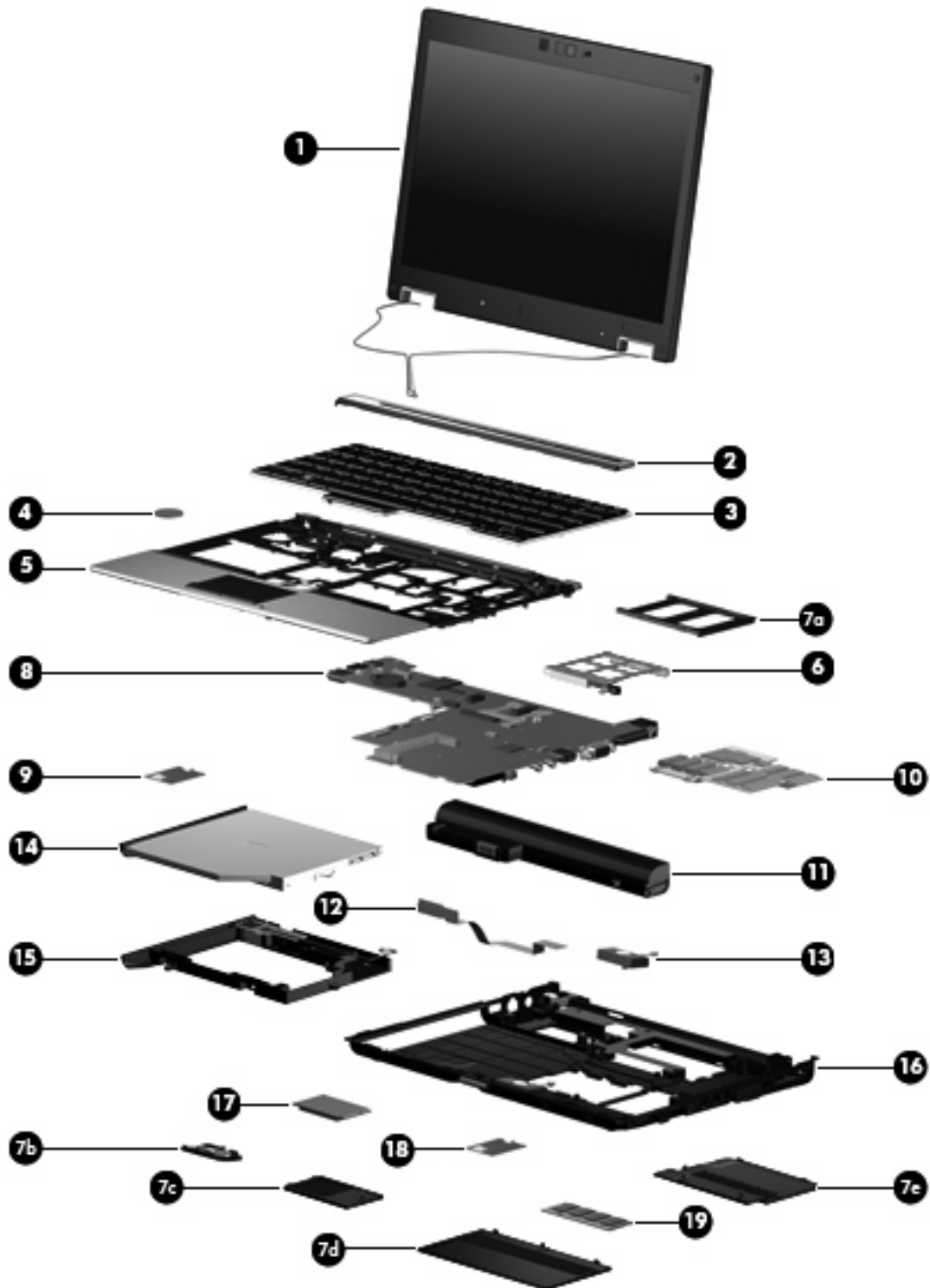

Item	Description	Spare part number
(1)	12.1-inch, WXGA AntiGlare display assembly (includes display panel cable, 2 WLAN antenna transceivers and cables, and microphones)	481103-001
Display assembly subcomponents (not illustrated):		

Item	Description	Spare part number
	Display bezel (includes HP logo and computer model number label)	481097-001
	Display bezel adhesive	497013-001
	Display panel cable	481099-001
	Display enclosure (includes HP logo, wireless antenna transceivers and cables, and microphone receiver and cable)	481100-001
	Display Hinge Kit (includes left and right hinges and brackets)	481098-001
(2)	Switch cover (includes display lid switch board and cable)	481093-001
(3)	Keyboards with pointing stick (include keyboard cable and pointing stick cable)	
	For use in Brazil	481112-201
	For use in French Canada	481112-121
	For use in Japan	481112-291
	For use in Latin America	481112-161
	For use in South Korea	481112-AD1
	For use in Taiwan	481112-AB1
	For use in the United States	481112-001
(4)	RTC battery	481089-001
(5)	Top cover (includes TouchPad board and cable, TouchPad button board and cable, and TouchPad bracket)	481111-001
(6)	PC Card assembly	481104-001
	Plastics Kit (see Plastics Kit on page 19 for more Plastics Kit spare part information):	481105-001
(7a)	PC Card slot bezel	
(7b)	Bluetooth® module compartment cover	
(7c)	Flash drive compartment cover	
(7d)	Memory module compartment cover	
(7e)	Rear cover	
(8)	System board (includes processor, replacement thermal material, and replacement thermal material cleaning kit)	481091-001
(9)	Modem modules	
	NOTE: The modem module spare part kits do not include a modem module cable. The modem module cable is included in the Cable Kit, spare part number 481092-001. See Cable Kit on page 20 for more Cable Kit spare part number information.	
	For use in all countries and regions except Australia and New Zealand	461750-001
	For use only in Australia and New Zealand	461750-002
(10)	Heat sink (includes replacement thermal material and replacement thermal material cleaning kit)	481110-001
(11)	Batteries	
	9-cell, 83.0-WH Li-ion	481088-001

Item	Description	Spare part number
	6-cell, 55.0-WH Li-ion	481087-001
	3-cell, 31.0-WH Li-ion	481086-001
(12)	LED board (includes cable and Mylar cover)	481090-001
(13)	Speaker	481109-001
(14)	DVD-ROM Drive (includes bezel and bracket)	481094-001
(15)	USB board (includes optical drive bezel and USB board cable)	481102-001
(16)	Base enclosure (includes display latch switch, battery release latch, and rubber feet)	481085-001
	Rubber Kit (not illustrated, contains 4 computer feet, 4 display bezel screw covers, and business card holder)	481106-001
(17)	Solid-state, parallel ATA (PATA) flash drives (include flash drive bracket)	
	2-GB solid-state, PATA flash drive	494352-001
	1-GB solid-state, PATA flash drive	481095-001
(18)	Broadcom 802.11a/b/g WLAN modules:	
	<ul style="list-style-type: none"> For use in Canada, the Cayman Islands, Guam, Puerto Rico, the U.S. Virgin Islands, and the United States 	441075-001
	<ul style="list-style-type: none"> For use in Afghanistan, Albania, Algeria, Andorra, Angola, Antigua and Barbuda, Argentina, Armenia, Aruba, Australia, Austria, Azerbaijan, the Bahamas, Bahrain, Bangladesh, Barbados, Belarus, Belgium, Belize, Benin, Bermuda, Bhutan, Bolivia, Bosnia and Herzegovina, Botswana, Brazil, the British Virgin Islands, Brunei, Bulgaria, Burkina Faso, Burundi, Cameroon, Cape Verde, the Central African Republic, Chad, Chile, the People's Republic of China, Colombia, Comoros, the Congo, Costa Rica, Croatia, Cyprus, the Czech Republic, Denmark, Djibouti, Dominica, the Dominican Republic, East Timor, Ecuador, Egypt, El Salvador, Equatorial Guinea, Eritrea, Estonia, Ethiopia, Fiji, Finland, France, French Guiana, Gabon, Gambia, Georgia, Germany, Ghana, Gibraltar, Greece, Grenada, Guadeloupe, Guatemala, Guinea, Bissau, Guyana, Haiti, Honduras, Hong Kong, Hungary, Iceland, India, Ireland, Israel, Italy, the Ivory Coast, Jamaica, Jordan, Kazakhstan, Kenya, Kiribati, Kyrgyzstan, Laos, Latvia, Lebanon, Lesotho, Liberia, Liechtenstein, Lithuania, Luxembourg, Macedonia, Madagascar, Malawi, Malaysia, the Maldives, Mali, Malta, the Marshall Islands, Martinique, Mauritania, Mauritius, Mexico, Micronesia, Monaco, Mongolia, Montenegro, Morocco, Mozambique, Namibia, Nauru, Nepal, the Nether Antilles, the Netherlands, New Zealand, Nicaragua, Niger, Nigeria, Norway, Oman, Pakistan, Palau, Panama, Papua New Guinea, Paraguay, Peru, the Philippines, Poland, Portugal, the Republic of Moldova, Romania, Russia, Rwanda, Samoa, San Marino, Sao Tome and Principe, Saudi Arabia, Senegal, Serbia, the Seychelles, Sierra Leone, Singapore, Slovakia, Slovenia, the Solomon Islands, Somalia, South Africa, South Korea, Spain, Sri Lanka, St. Kitts and St. Nevis, St. Lucia, St. Vincent and the Grenadines, Suriname, Swaziland, Sweden, Switzerland, Taiwan, Tajikistan, Tanzania, Togo, Tonga, Trinidad and Tobago, Tunisia, Turkey, Turkmenistan, Tuvalu, Uganda, Ukraine, the United Arab Emirates, the United Kingdom, Uruguay, Uzbekistan, Vanuatu, Venezuela, Vietnam, Yemen, Zaire, Zambia, and Zimbabwe 	441075-002
	<ul style="list-style-type: none"> For use in Japan 	441075-291
(19)	1024-MB memory module (PC2-5300, 667-MHz, DDR2)	481101-001
	Smart card reader (not illustrated)	481108-001
	Cable Kit (not illustrated; see Cable Kit on page 20 for more Cable Kit spare part number information)	480092-001

Plastics Kit

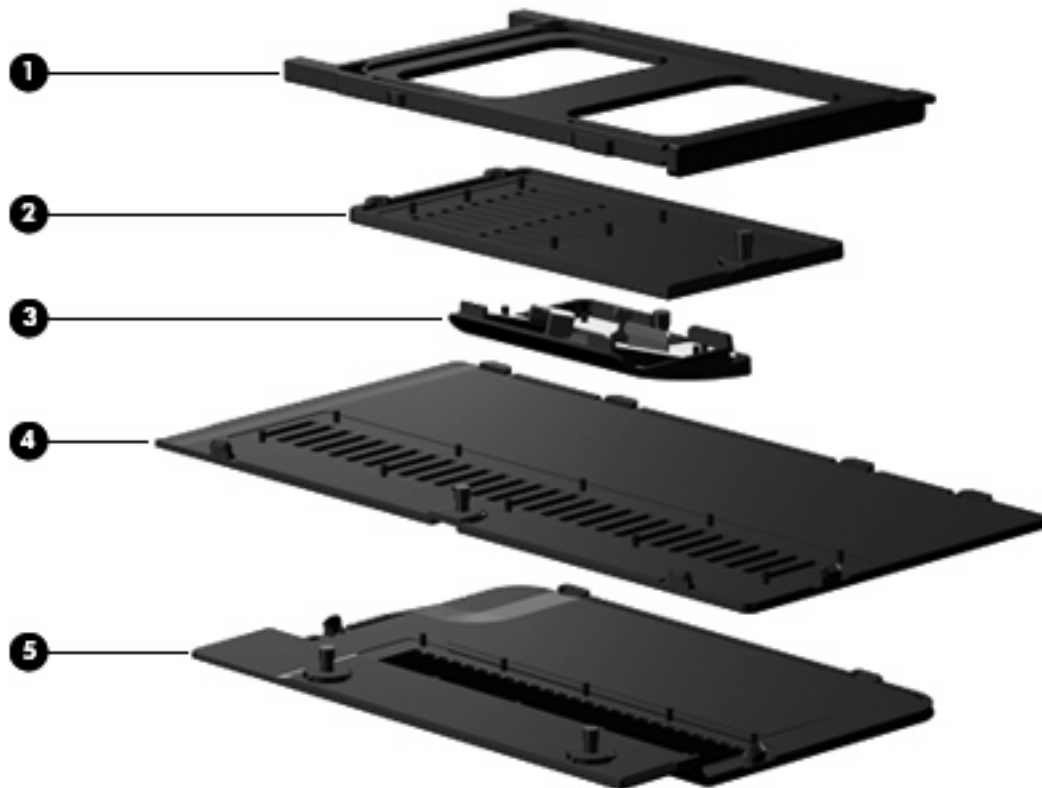

Item	Description	Spare part number
	Plastics Kit:	481105-001
(1)	PC Card slot bezel	
(2)	Flash drive compartment cover (includes 2 captive screws, secured by C-clips)	
(3)	Bluetooth module compartment cover (includes one captive screw, secured by a C-clip)	
(4)	Memory module compartment cover (includes one captive screw, secured by a C-clip)	
(5)	Rear cover (includes 2 captive screws, secured by C-clips)	

Cable Kit

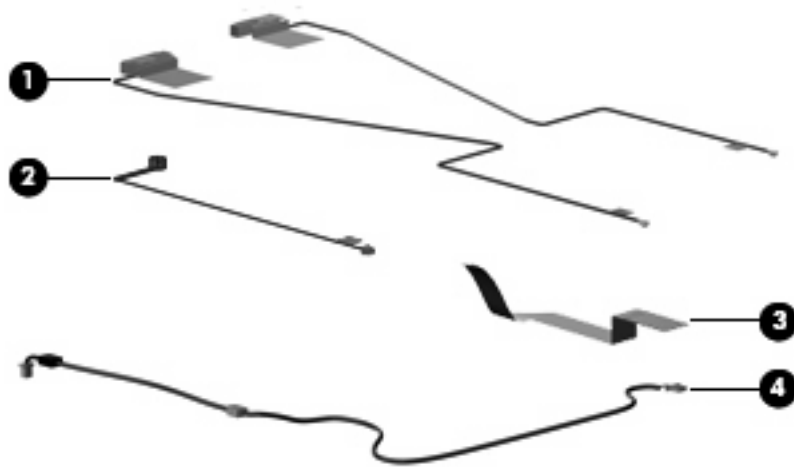

Item	Description	Spare part number
	Cable Kit:	481092-001
(1)	Wireless antenna transceivers and cables	
(2)	Microphone receiver and cable	
(3)	LED board cable	
(4)	Modem module cable	

Miscellaneous parts

Description	Spare part number
65-W, 3-prong, PFC AC adapter	463958-001
Power cord	490371-001
Screw Kit	481107-001
<ul style="list-style-type: none"> • Phillips PM2.5×11.0 captive screw • Phillips PM2.5×6.0 captive screw • Phillips PM2.5×4.0 screw • Phillips PM2.0×6.0 screw • Phillips PM2.0×5.0 screw • Phillips PM2.0×4.0 screw • Torx T8M2.5×10.0 captive screw • Torx T8M2.5×6.0 screw • Torx T8M2.0×5.0 screw 	

Sequential part number listing

Spare part number	Description
441075-001	Broadcom 802.11a/b/g WLAN module for use in Canada, the Cayman Islands, Guam, Puerto Rico, the U.S. Virgin Islands, and the United States
441075-002	Broadcom 802.11a/b/g WLAN module for use in Afghanistan, Albania, Algeria, Andorra, Angola, Antigua and Barbuda, Argentina, Armenia, Aruba, Australia, Austria, Azerbaijan, the Bahamas, Bahrain, Bangladesh, Barbados, Belarus, Belgium, Belize, Benin, Bermuda, Bhutan, Bolivia, Bosnia and Herzegovina, Botswana, Brazil, the British Virgin Islands, Brunei, Bulgaria, Burkina Faso, Burundi, Cameroon, Cape Verde, the Central African Republic, Chad, Chile, the People's Republic of China, Colombia, Comoros, the Congo, Costa Rica, Croatia, Cyprus, the Czech Republic, Denmark, Djibouti, Dominica, the Dominican Republic, East Timor, Ecuador, Egypt, El Salvador, Equatorial Guinea, Eritrea, Estonia, Ethiopia, Fiji, Finland, France, French Guiana, Gabon, Gambia, Georgia, Germany, Ghana, Gibraltar, Greece, Grenada, Guadeloupe, Guatemala, Guinea, Bissau, Guyana, Haiti, Honduras, Hong Kong, Hungary, Iceland, India, Ireland, Israel, Italy, the Ivory Coast, Jamaica, Jordan, Kazakhstan, Kenya, Kiribati, Kyrgyzstan, Laos, Latvia, Lebanon, Lesotho, Liberia, Liechtenstein, Lithuania, Luxembourg, Macedonia, Madagascar, Malawi, Malaysia, the Maldives, Mali, Malta, the Marshall Islands, Martinique, Mauritania, Mauritius, Mexico, Micronesia, Monaco, Mongolia, Montenegro, Morocco, Mozambique, Namibia, Nauru, Nepal, the Nether Antilles, the Netherlands, New Zealand, Nicaragua, Niger, Nigeria, Norway, Oman, Pakistan, Palau, Panama, Papua New Guinea, Paraguay, Peru, the Philippines, Poland, Portugal, the Republic of Moldova, Romania, Russia, Rwanda, Samoa, San Marino, Sao Tome and Principe, Saudi Arabia, Senegal, Serbia, the Seychelles, Sierra Leone, Singapore, Slovakia, Slovenia, the Solomon Islands, Somalia, South Africa, South Korea, Spain, Sri Lanka, St. Kitts and St. Nevis, St. Lucia, St. Vincent and the Grenadines, Suriname, Swaziland, Sweden, Switzerland, Taiwan, Tajikistan, Tanzania, Togo, Tonga, Trinidad and Tobago, Tunisia, Turkey, Turkmenistan, Tuvalu, Uganda, Ukraine, the United Arab Emirates, the United Kingdom, Uruguay, Uzbekistan, Vanuatu, Venezuela, Vietnam, Yemen, Zaire, Zambia, and Zimbabwe
441075-291	Broadcom 802.11a/b/g WLAN module for use in Japan
461750-001	Modem module for use in all countries and regions except Australia and New Zealand NOTE: The modem module spare part kits do not include a modem module cable. The modem module cable is included in the Cable Kit, spare part number 481092-001. See Cable Kit on page 20 for more Cable Kit spare part number information.
461750-002	Modem module for use only in Australia and New Zealand NOTE: The modem module spare part kits do not include a modem module cable. The modem module cable is included in the Cable Kit, spare part number 481092-001. See Cable Kit on page 20 for more Cable Kit spare part number information.
463958-001	65-W, 3-prong, PFC AC adapter
481085-001	Base enclosure (includes display latch switch, battery release latch, and rubber feet)
481086-001	3-cell, 31.0-WH, Li-ion battery
481087-001	6-cell, 55.0-WH, Li-ion battery
481088-001	9-cell, 83.0-WH, Li-ion battery
481089-001	RTC battery
481090-001	LED board (includes cable and Mylar cover)
481091-001	System board (includes processor, replacement thermal material, and replacement thermal material cleaning kit)
481092-001	Cable Kit (see Cable Kit on page 20 for more Cable Kit spare part number information)
481093-001	Switch cover (includes display lid switch board and cable)
481094-001	DVD-ROM Drive (includes bezel and bracket)

Spare part number	Description
481095-001	1-GB solid-state, PATA flash drive (includes flash drive bracket)
481097-001	Display bezel (includes HP logo and model number label)
481098-001	Display hinges (includes left and right hinges and brackets)
481099-001	Display panel cable
481100-001	Display enclosure (includes wireless antenna transceivers and cables and microphone receiver and cable)
481101-001	1024-MB memory module (PC2-5300, 667-MHz, DDR2)
481102-001	USB board (includes optical drive bezel and USB board cable)
481103-001	12.1-inch, WXGA AntiGlare display assembly (includes 2 WLAN antenna transceivers and cables and microphones)
481104-001	PC Card assembly
481105-001	Plastics Kit (see Plastics Kit on page 19 for more Plastics Kit spare part information):
481106-001	Rubber Kit (contains 4 computer feet, 4 display bezel screw covers, and business card holder)
481107-001	Screw Kit
481108-001	Smart card reader
481109-001	Speaker
481110-001	Heat sink (includes replacement thermal material and replacement thermal material cleaning kit)
481111-001	Top cover (includes TouchPad board and cable, TouchPad button board and cable, and TouchPad bracket)
481112-001	Keyboard with pointing stick for use in the United States (includes keyboard cable and pointing stick cable)
481112-121	Keyboard with pointing stick for use in French Canada (includes keyboard cable and pointing stick cable)
481112-161	Keyboard with pointing stick for use in Latin America (includes keyboard cable and pointing stick cable)
481112-201	Keyboard with pointing stick for use in Brazil (includes keyboard cable and pointing stick cable)
481112-291	Keyboard with pointing stick for use in Japan (includes keyboard cable and pointing stick cable)
481112-AB1	Keyboard with pointing stick for use in Taiwan (includes keyboard cable and pointing stick cable)
481112-AD1	Keyboard with pointing stick for use in South Korea (includes keyboard cable and pointing stick cable)
490371-001	Power cord
494352-001	2-GB solid-state, PATA flash drive (includes flash drive bracket)
497013-001	Display bezel adhesive

4 Removal and replacement procedures

Preliminary replacement requirements

Tools required

You will need the following tools to complete the removal and replacement procedures:

- Flat-bladed screwdriver
- Magnetic screwdriver
- Phillips P0 and P1 screwdrivers
- Torx T8 screwdriver

Service considerations

The following sections include some of the considerations that you must keep in mind during disassembly and assembly procedures.

 **NOTE:** As you remove each subassembly from the computer, place the subassembly (and all accompanying screws) away from the work area to prevent damage.

Plastic parts

Using excessive force during disassembly and reassembly can damage plastic parts. Use care when handling the plastic parts. Apply pressure only at the points designated in the maintenance instructions.

Cables and connectors

-
- △ **CAUTION:** When servicing the computer, be sure that cables are placed in their proper locations during the reassembly process. Improper cable placement can damage the computer.
-

Cables must be handled with extreme care to avoid damage. Apply only the tension required to unseat or seat the cables during removal and insertion. Handle cables by the connector whenever possible. In all cases, avoid bending, twisting, or tearing cables. Be sure that cables are routed in such a way that they cannot be caught or snagged by parts being removed or replaced. Handle flex cables with extreme care; these cables tear easily.

Drive handling

-
- △ **CAUTION:** Drives are fragile components that must be handled with care. To prevent damage to the computer, damage to a drive, or loss of information, observe these precautions:
-

Before removing or inserting a flash drive, shut down the computer.

Before handling a drive, be sure that you are discharged of static electricity. While handling a drive, avoid touching the connector.

Before removing a diskette drive or optical drive, be sure that a diskette or disc is not in the drive and be sure that the optical drive tray is closed.

Handle drives on surfaces covered with at least one inch of shock-proof foam.

Avoid dropping drives from any height onto any surface.

After removing a flash drive, an optical drive, or a diskette drive, place it in a static-proof bag.

Avoid exposing a flash drive to products that have magnetic fields, such as monitors or speakers.

Avoid exposing a drive to temperature extremes or liquids.

If a drive must be mailed, place the drive in a bubble pack mailer or other suitable form of protective packaging and label the package "FRAGILE."

Grounding guidelines

Electrostatic discharge damage

Electronic components are sensitive to electrostatic discharge (ESD). Circuitry design and structure determine the degree of sensitivity. Networks built into many integrated circuits provide some protection, but in many cases, ESD contains enough power to alter device parameters or melt silicon junctions.

A discharge of static electricity from a finger or other conductor can destroy static-sensitive devices or microcircuitry. Even if the spark is neither felt nor heard, damage may have occurred.

An electronic device exposed to ESD may not be affected at all and can work perfectly throughout a normal cycle. Or the device may function normally for a while, then degrade in the internal layers, reducing its life expectancy.

- △ **CAUTION:** To prevent damage to the computer when you are removing or installing internal components, observe these precautions:

Keep components in their electrostatic-safe containers until you are ready to install them.

Before touching an electronic component, discharge static electricity by using the guidelines described in this section.

Avoid touching pins, leads, and circuitry. Handle electronic components as little as possible.

If you remove a component, place it in an electrostatic-safe container.

The following table shows how humidity affects the electrostatic voltage levels generated by different activities.

- △ **CAUTION:** A product can be degraded by as little as 700 V.

Typical electrostatic voltage levels			
Event	Relative humidity		
	10%	40%	55%
Walking across carpet	35,000 V	15,000 V	7,500 V
Walking across vinyl floor	12,000 V	5,000 V	3,000 V
Motions of bench worker	6,000 V	800 V	400 V
Removing DIPS from plastic tube	2,000 V	700 V	400 V
Removing DIPS from vinyl tray	11,500 V	4,000 V	2,000 V
Removing DIPS from Styrofoam	14,500 V	5,000 V	3,500 V
Removing bubble pack from PCB	26,500 V	20,000 V	7,000 V
Packing PCBs in foam-lined box	21,000 V	11,000 V	5,000 V

Packaging and transporting guidelines

Follow these grounding guidelines when packaging and transporting equipment:

- To avoid hand contact, transport products in static-safe tubes, bags, or boxes.
- Protect ESD-sensitive parts and assemblies with conductive or approved containers or packaging.
- Keep ESD-sensitive parts in their containers until the parts arrive at static-free workstations.
- Place items on a grounded surface before removing items from their containers.
- Always be properly grounded when touching a component or assembly.
- Store reusable ESD-sensitive parts from assemblies in protective packaging or nonconductive foam.
- Use transporters and conveyors made of antistatic belts and roller bushings. Be sure that mechanized equipment used for moving materials is wired to ground and that proper materials are selected to avoid static charging. When grounding is not possible, use an ionizer to dissipate electric charges.

Workstation guidelines

Follow these grounding workstation guidelines:

- Cover the workstation with approved static-shielding material.
- Use a wrist strap connected to a properly grounded work surface and use properly grounded tools and equipment.
- Use conductive field service tools, such as cutters, screwdrivers, and vacuums.
- When fixtures must directly contact dissipative surfaces, use fixtures made only of static-safe materials.
- Keep the work area free of nonconductive materials, such as ordinary plastic assembly aids and Styrofoam.
- Handle ESD-sensitive components, parts, and assemblies by the case or PCM laminate. Handle these items only at static-free workstations.
- Avoid contact with pins, leads, or circuitry.
- Turn off power and input signals before inserting or removing connectors or test equipment.

Equipment guidelines

Grounding equipment must include either a wrist strap or a foot strap at a grounded workstation.

- When seated, wear a wrist strap connected to a grounded system. Wrist straps are flexible straps with a minimum of one megohm $\pm 10\%$ resistance in the ground cords. To provide proper ground, wear a strap snugly against the skin at all times. On grounded mats with banana-plug connectors, use alligator clips to connect a wrist strap.
- When standing, use foot straps and a grounded floor mat. Foot straps (heel, toe, or boot straps) can be used at standing workstations and are compatible with most types of shoes or boots. On conductive floors or dissipative floor mats, use foot straps on both feet with a minimum of one megohm resistance between the operator and ground. To be effective, the conductive must be worn in contact with the skin.

The following grounding equipment is recommended to prevent electrostatic damage:

- Antistatic tape
- Antistatic smocks, aprons, and sleeve protectors
- Conductive bins and other assembly or soldering aids
- Nonconductive foam
- Conductive tabletop workstations with ground cords of one megohm resistance
- Static-dissipative tables or floor mats with hard ties to the ground
- Field service kits
- Static awareness labels
- Material-handling packages
- Nonconductive plastic bags, tubes, or boxes
- Metal tote boxes
- Electrostatic voltage levels and protective materials

The following table lists the shielding protection provided by antistatic bags and floor mats.

Material	Use	Voltage protection level
Antistatic plastic	Bags	1,500 V
Carbon-loaded plastic	Floor mats	7,500 V
Metallized laminate	Floor mats	5,000 V

Unknown user password

If the computer you are servicing has an unknown user password, follow these steps to clear the password:

 **NOTE:** These steps also clear CMOS.

1. Shut down the computer.
2. Disconnect all external devices connected to the computer.
3. Disconnect the power from the computer by first unplugging the power cord from the AC outlet and then unplugging the AC adapter from the computer.
4. Remove the battery (see [Battery on page 30](#)).
5. Remove the real-time clock (RTC) battery (see [RTC battery on page 46](#)).
6. Wait approximately 5 minutes.
7. Replace the RTC battery and reassemble the computer.
8. Connect AC power to the computer. Do not reinsert any batteries at this time.
9. Turn on the computer.

All passwords and all CMOS settings have been cleared.

Component replacement procedures

This chapter provides removal and replacement procedures.

There are as many as 60 screws, in 9 different sizes, that must be removed, replaced, or loosened when servicing the computer. Make special note of each screw size and location during removal and replacement.

Serial number

Report the computer serial number to HP when requesting information or ordering spare parts. The serial number is located on the bottom of the computer.



Computer feet

The computer feet are adhesive-backed rubber pads. The feet are included in the Rubber Kit, spare part number 481106-001. There are 4 rubber feet that attach to the base enclosure in the locations illustrated below.

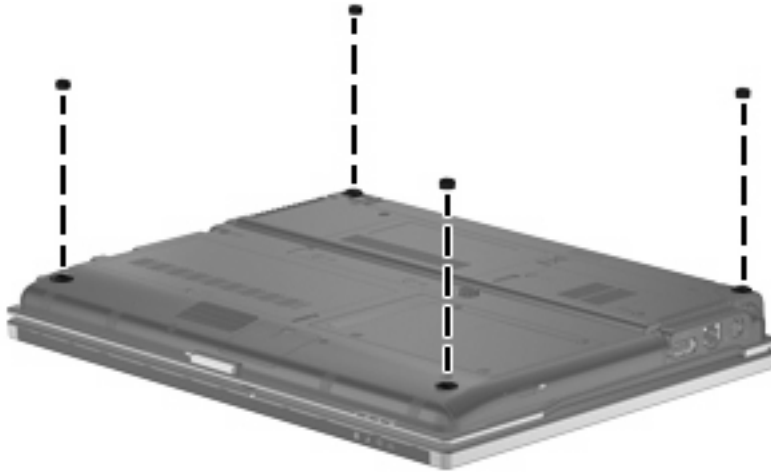

Battery

Description	Spare part number
9-cell, 83.0-WH, Li-ion battery	481088-001
6-cell, 55.0-WH, Li-ion battery	481087-001
3-cell, 31.0-WH, Li-ion battery	481086-001

Before disassembling the computer, follow these steps:

1. Shut down the computer.
2. Disconnect all external devices connected to the computer.
3. Disconnect the power from the computer by first unplugging the power cord from the AC outlet and then unplugging the AC adapter from the computer.

Remove the battery:

1. Turn the computer upside down on a flat surface, with the battery bay toward you.
2. Slide the battery release latches **(1)** to release the battery.

3. Remove the battery **(2)** from the computer.

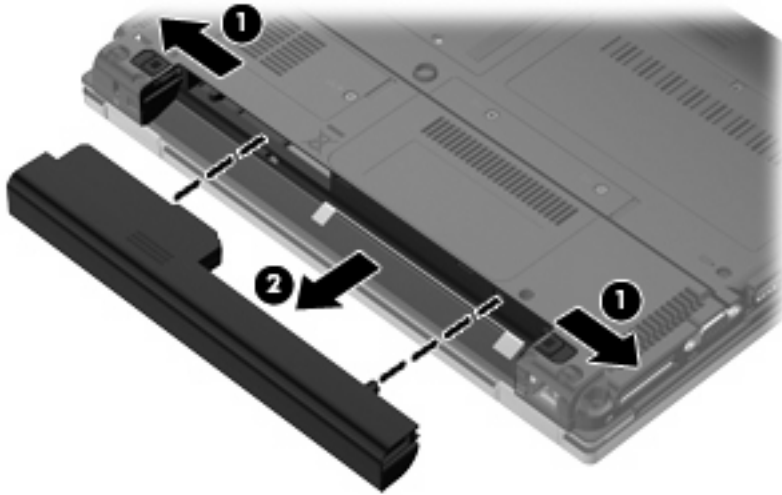

Install the battery by inserting it into the battery bay until you hear a click.

Memory module

Description	Spare part number
1024-MB (PC2-5300, 667-MHz, DDR2)	481101-001

Before removing the memory module, follow these steps:

1. Shut down the computer.
2. Disconnect all external devices connected to the computer.
3. Disconnect the power from the computer by first unplugging the power cord from the AC outlet and then unplugging the AC adapter from the computer.
4. Remove the battery (see [Battery on page 30](#)).

Remove the memory module:

1. Loosen the Phillips PM2.5×6.0 captive screw (1) that secures the memory module compartment cover to the computer.
2. Lift the front edge of the cover (2), swing it back, and remove the cover (3). The memory module compartment cover is included in the Plastics Kit, spare part number 481105-001.

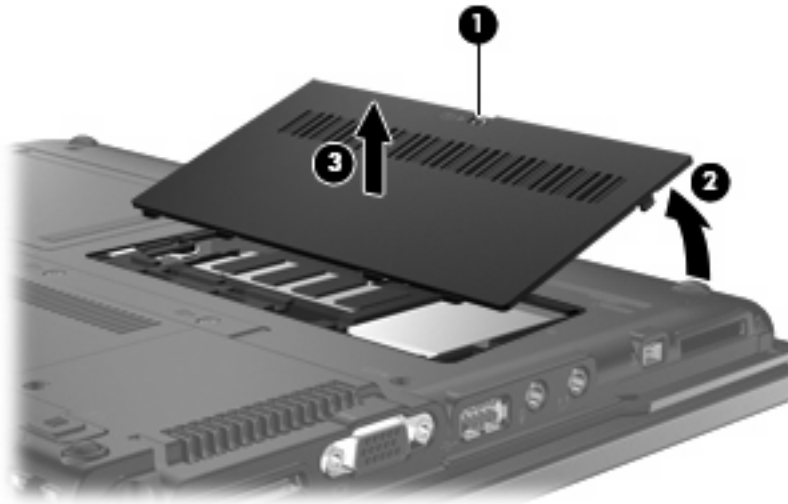

3. Spread the retaining tabs (1) on each side of the memory module slot to release the memory module. (The edge of the module opposite the slot rises away from the computer.)

4. Remove the memory module (2) by pulling the module away from the slot at an angle.

 **NOTE:** The memory module is designed with a notch (3) to prevent incorrect installation into the memory module slot.

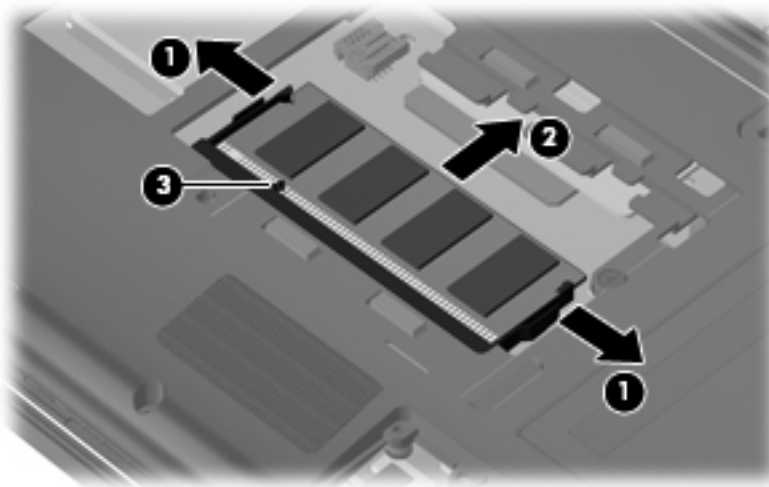

Reverse this procedure to install the memory module.

WLAN module

Description	Spare part number
Broadcom 802.11a/b/g WLAN modules:	
<ul style="list-style-type: none">For use in Canada, the Cayman Islands, Guam, Puerto Rico, the U.S. Virgin Islands, and the United States	441075-001
<ul style="list-style-type: none">For use in Afghanistan, Albania, Algeria, Andorra, Angola, Antigua and Barbuda, Argentina, Armenia, Aruba, Australia, Austria, Azerbaijan, the Bahamas, Bahrain, Bangladesh, Barbados, Belarus, Belgium, Belize, Benin, Bermuda, Bhutan, Bolivia, Bosnia and Herzegovina, Botswana, Brazil, the British Virgin Islands, Brunei, Bulgaria, Burkina Faso, Burundi, Cameroon, Cape Verde, the Central African Republic, Chad, Chile, the People's Republic of China, Colombia, Comoros, the Congo, Costa Rica, Croatia, Cyprus, the Czech Republic, Denmark, Djibouti, Dominica, the Dominican Republic, East Timor, Ecuador, Egypt, El Salvador, Equatorial Guinea, Eritrea, Estonia, Ethiopia, Fiji, Finland, France, French Guiana, Gabon, Gambia, Georgia, Germany, Ghana, Gibraltar, Greece, Grenada, Guadeloupe, Guatemala, Guinea, Bissau, Guyana, Haiti, Honduras, Hong Kong, Hungary, Iceland, India, Ireland, Israel, Italy, the Ivory Coast, Jamaica, Jordan, Kazakhstan, Kenya, Kiribati, Kyrgyzstan, Laos, Latvia, Lebanon, Lesotho, Liberia, Liechtenstein, Lithuania, Luxembourg, Macedonia, Madagascar, Malawi, Malaysia, the Maldives, Mali, Malta, the Marshall Islands, Martinique, Mauritania, Mauritius, Mexico, Micronesia, Monaco, Mongolia, Montenegro, Morocco, Mozambique, Namibia, Nauru, Nepal, the Nether Antilles, the Netherlands, New Zealand, Nicaragua, Niger, Nigeria, Norway, Oman, Pakistan, Palau, Panama, Papua New Guinea, Paraguay, Peru, the Philippines, Poland, Portugal, the Republic of Moldova, Romania, Russia, Rwanda, Samoa, San Marino, Sao Tome and Principe, Saudi Arabia, Senegal, Serbia, the Seychelles, Sierra Leone, Singapore, Slovakia, Slovenia, the Solomon Islands, Somalia, South Africa, South Korea, Spain, Sri Lanka, St. Kitts and St. Nevis, St. Lucia, St. Vincent and the Grenadines, Suriname, Swaziland, Sweden, Switzerland, Taiwan, Tajikistan, Tanzania, Togo, Tonga, Trinidad and Tobago, Tunisia, Turkey, Turkmenistan, Tuvalu, Uganda, Ukraine, the United Arab Emirates, the United Kingdom, Uruguay, Uzbekistan, Vanuatu, Venezuela, Vietnam, Yemen, Zaire, Zambia, and Zimbabwe	441075-002
<ul style="list-style-type: none">For use in Japan	441075-291

Before removing the WLAN module, follow these steps:

1. Shut down the computer.
2. Disconnect all external devices connected to the computer.
3. Disconnect the power from the computer by first unplugging the power cord from the AC outlet and then unplugging the AC adapter from the computer.
4. Remove the battery (see [Battery on page 30](#)).

Remove the WLAN module:

1. Loosen the Phillips PM2.5×6.0 captive screw **(1)** that secures the memory module compartment cover to the computer.

2. Lift the front edge of the memory module compartment cover (2), swing it back, and remove the cover (3). The memory module compartment cover is included in the Plastics Kit, spare part number 481105-001.

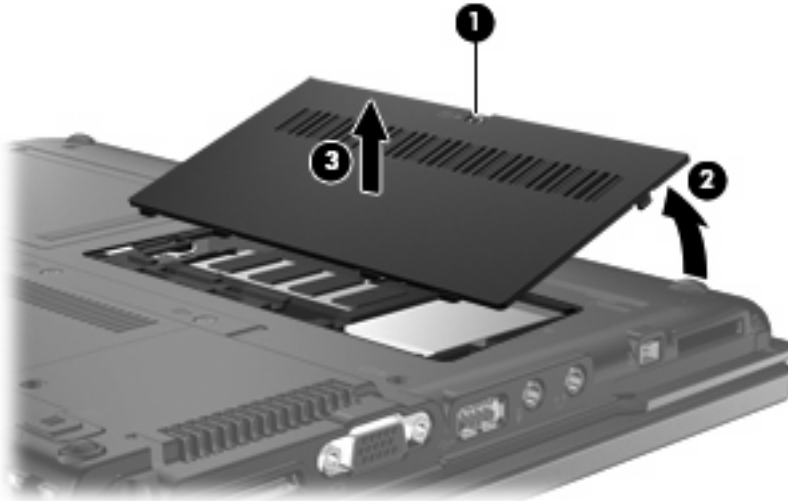

3. Disconnect the WLAN antenna cables (1) from the terminals on the WLAN module.

 **NOTE:** The black WLAN antenna cable is connected to the WLAN module “Main” terminal. The white WLAN antenna cable is connected to the WLAN module “Aux” terminal.

4. Remove the two Phillips PM2.0×4.0 screws (2) that secure the WLAN module to the computer. (The edge of the module opposite the slot rises away from the computer.)
5. Remove the WLAN module (3) by pulling the module away from the slot at an angle.

 **NOTE:** WLAN modules are designed with a notch (4) to prevent incorrect installation.

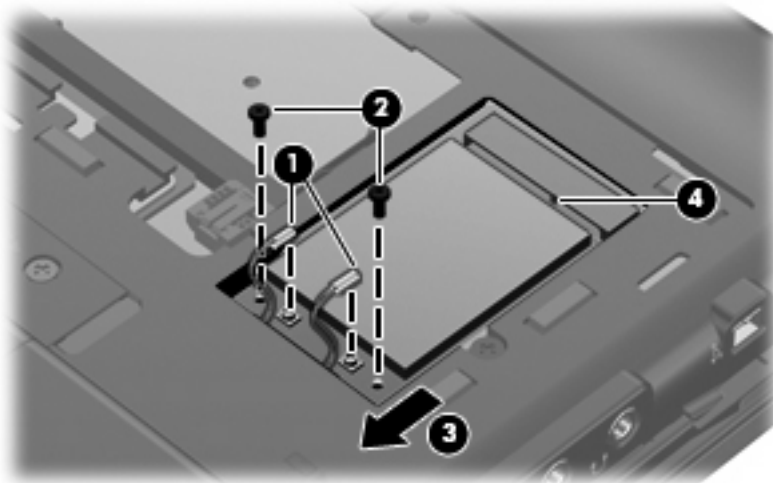

Reverse this procedure to install the WLAN module.

Flash drive

 **NOTE:** All flash drive spare part kits include a flash drive bracket).

Description	Spare part number
2-GB solid-state, PATA flash drive	494352-001
1-GB solid-state, PATA flash drive	481095-001

Before removing the flash drive, follow these steps:

1. Shut down the computer.
2. Disconnect all external devices connected to the computer.
3. Disconnect the power from the computer by first unplugging the power cord from the AC outlet and then unplugging the AC adapter from the computer.
4. Remove the battery (see [Battery on page 30](#)).

Remove the flash drive:

1. Position the computer with the front toward you.
2. Loosen the Phillips PM2.5×6.0 captive screw (1) that secures the flash drive compartment cover to the computer.
3. Lift the left side of the flash drive compartment cover (2), swing it to right, and remove the cover (3). The flash drive compartment cover is included in the Plastics Kit, spare part number 481105-001.

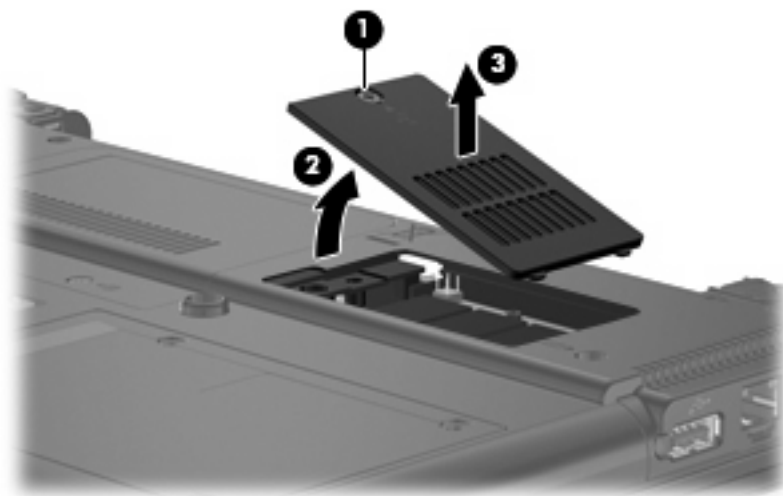

△ **CAUTION:** The flash drive is connected to the system board by a delicate, multiple-pin connector. The flash drive must be lifted straight up to be disconnected and removed. Any rocking motion during removal can damage the flash drive pins on the system board.

4. Lift the flash drive straight up to disconnect it from the system board (1).

 **NOTE:** When installing the flash drive, be sure that the alignment pin on the system board is aligned with the hole (2) on the flash drive.

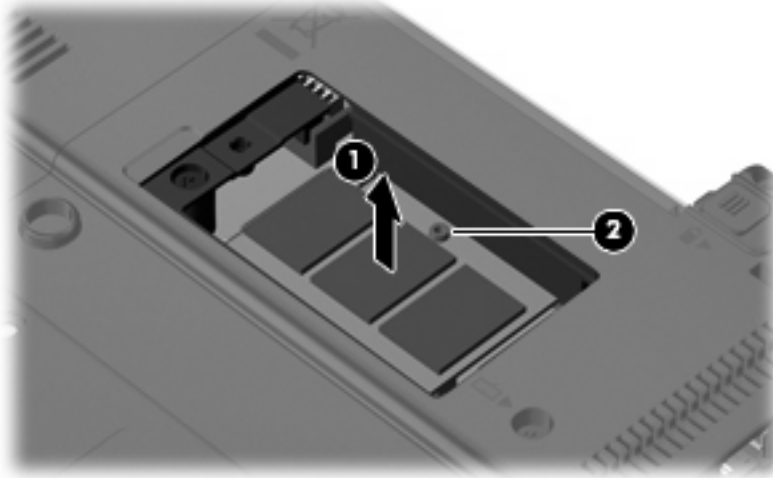

Reverse this procedure to install the flash drive.

Optical drive

Description	Spare part number
DVD-ROM Drive (includes bezel and bracket)	481094-001

Before removing the optical drive, follow these steps:

1. Shut down the computer.
2. Disconnect all external devices connected to the computer.
3. Disconnect the power from the computer by first unplugging the power cord from the AC outlet and then unplugging the AC adapter from the computer.
4. Remove the battery (see [Battery on page 30](#)).

Remove the optical drive:

1. Remove the memory module compartment cover (see [Memory module on page 32](#)).
2. Position the computer with the right side toward you.
3. Remove the Mylar screw cover (1) that secures the optical drive retention screw. The Mylar screw cover is available in the Rubber Kit, spare part number 481106-001.
4. Remove the two Torx T8M2.0×5.0 screws (2) that secure the optical drive to the computer.
5. Insert a thin tool, such as a paper clip (3), into the release access. (The optical drive disc tray is partially ejected from the optical drive.)
6. Remove the optical drive (4) from the computer.

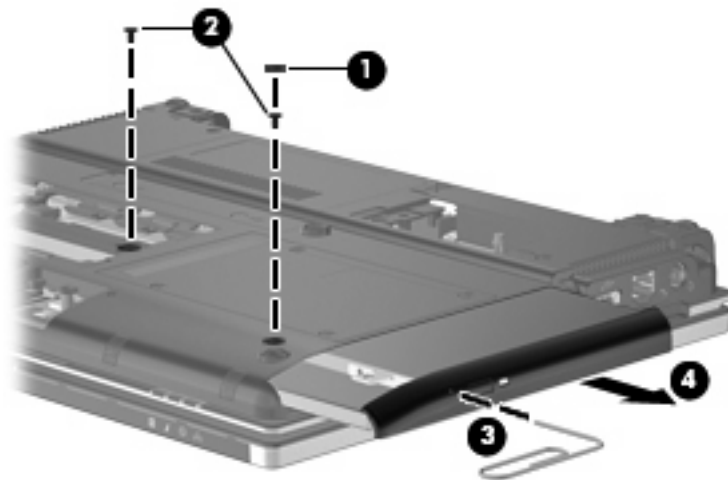

7. If it is necessary to replace the optical drive bracket, position the optical drive with the rear toward you.
8. Remove the two Phillips PM2.0×4.0 screws (1) that secure the optical drive bracket to the optical drive.

9. Remove the optical drive bracket (2).

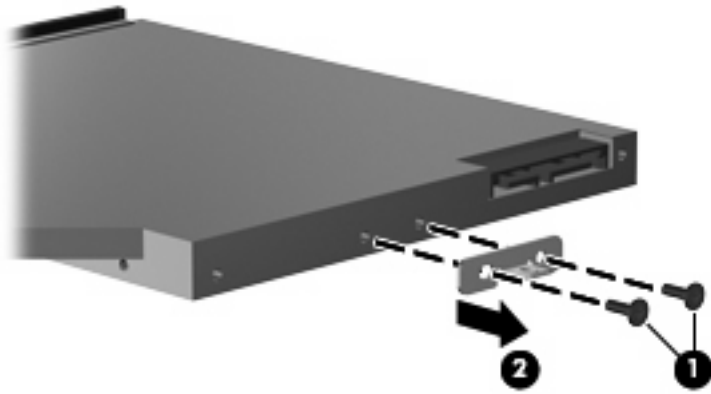

Reverse this procedure to reassemble and install an optical drive.

Switch cover and keyboard

Description		Spare part number	
Switch cover (includes display lid switch board and cable)		481093-001	
Keyboards			
For use in the following countries or regions	Spare part number	For use in the following countries or regions	Spare part number
Brazil	481112-201	South Korea	481112-AD1
French Canada	481112-121	Taiwan	481112-AB1
Japan	481112-291	The United States	481112-001
Latin America	481112-161		

Before removing the switch cover and keyboard, follow these steps:

1. Shut down the computer.
2. Disconnect all external devices connected to the computer.
3. Disconnect the power from the computer by first unplugging the power cord from the AC outlet and then unplugging the AC adapter from the computer.
4. Remove the battery (see [Battery on page 30](#)).

Remove the switch cover and keyboard:

1. Remove the Torx8 T8M2.5×6.0 screw that secures the switch cover to the computer.

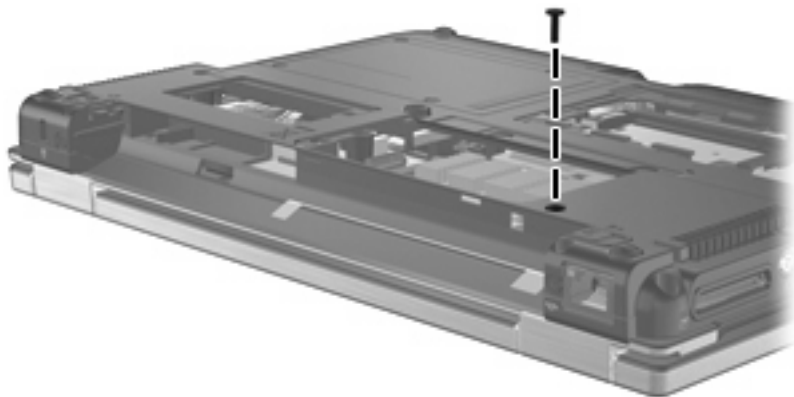

2. Loosen the two Phillips PM2.5×6.0 captive screws (1) that secure the rear cover to the computer.

3. Lift the front edge of the rear cover (2), swing it back, and remove it (3). The rear cover is included in the Plastics Kit, spare part number 481105-001.

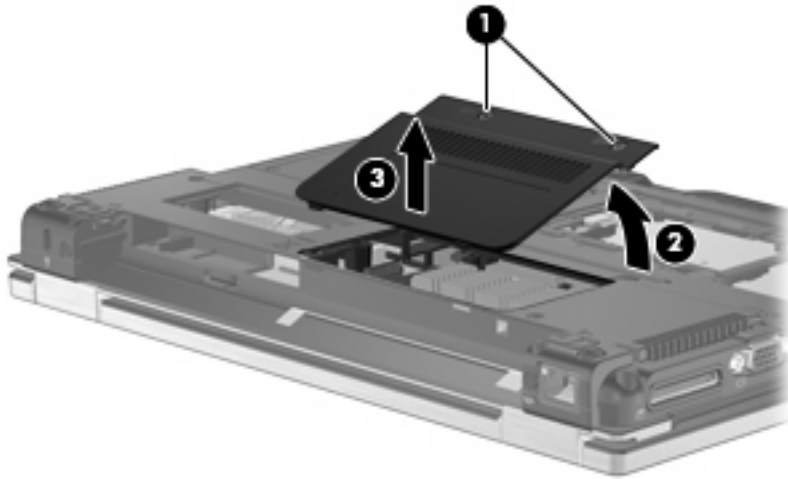

4. Position the computer with the front toward you.
5. Loosen the five Phillips PM2.5×11.0 captive screws that secure the keyboard to the computer.

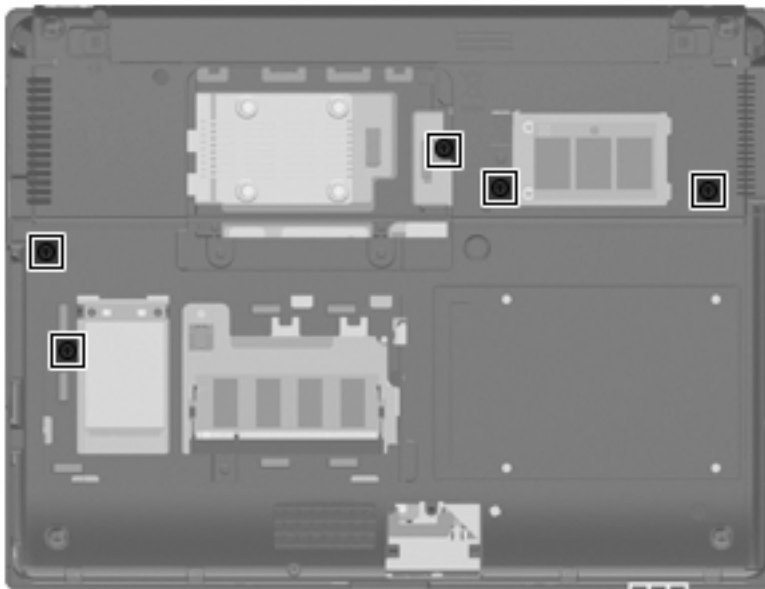

6. Turn the computer display-side up, with the front toward you.
7. Open the computer as far as possible.
8. Slide the switch cover to the right (1) to disengage it from the computer.

9. Lift the switch cover (2) as far as the two switch cover cables allow.

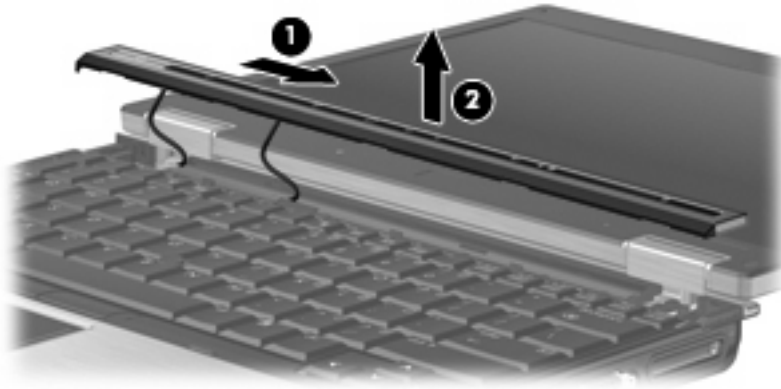

10. Lift the rear edge of the keyboard and swing it up and forward until it rests upside down on the palm rest.



11. Release the zero insertion force (ZIF) connector (1) to which the keyboard cable is attached, and disconnect the keyboard cable (2) from the system board.
12. Release the ZIF connector (3) to which the pointing stick cable is attached, and disconnect the pointing stick cable (4) from the system board.

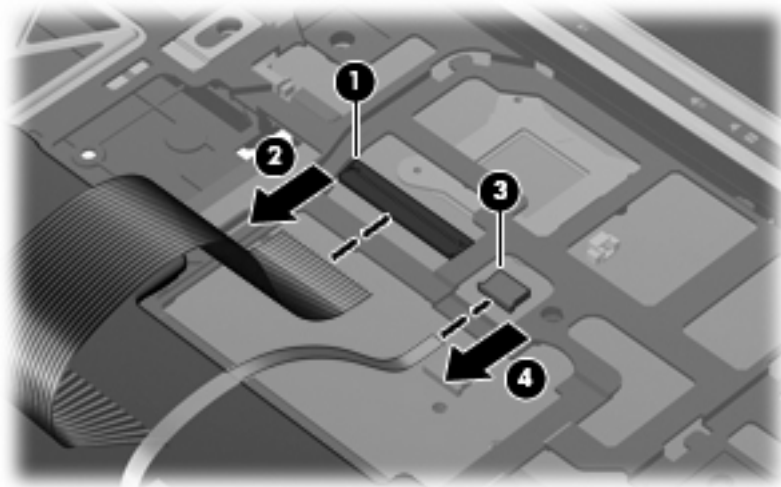

13. Remove the keyboard.

14. Disconnect the display lid switch cable (1) and the LED board cable (2) from the system board.
15. Remove the switch cover (3).

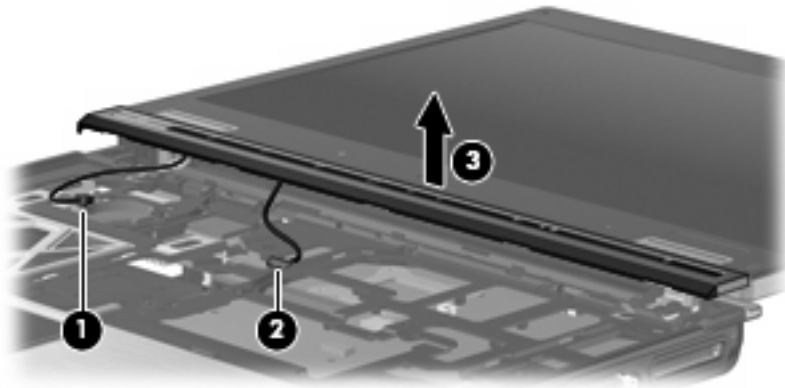

Reverse this procedure to install the switch cover and keyboard.

USB board and optical drive bezel

Description	Spare part number
USB board (includes optical drive bezel and cable)	481102-001

Before removing the USB board and optical drive bezel, follow these steps:

1. Shut down the computer.
2. Disconnect all external devices connected to the computer.
3. Disconnect the power from the computer by first unplugging the power cord from the AC outlet and then unplugging the AC adapter from the computer.
4. Remove the battery (see [Battery on page 30](#)).
5. Remove the switch cover and keyboard (see [Switch cover and keyboard on page 40](#)).

Remove the USB board and optical drive bezel:

1. Turn the computer upside down, with the front toward you.
2. Remove the two Phillips PM2.0×4.0 screws that secure the optical drive bezel to the computer.

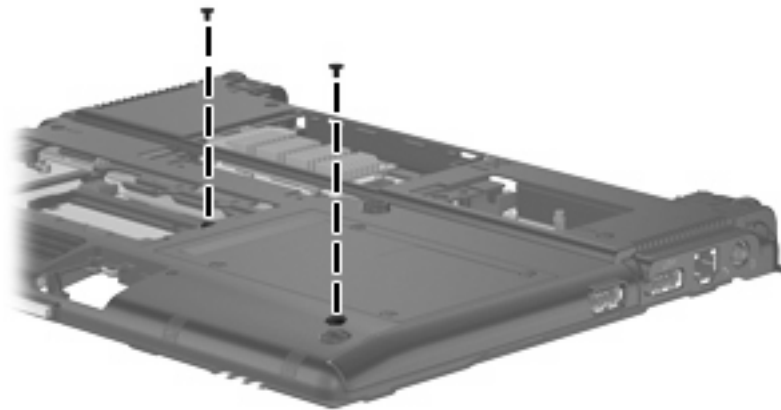

3. Turn the computer right-side up, with the front toward you.
4. Disconnect the USB board cable (1) from the system board.

5. Release the optical drive bezel (2) by sliding it out of the base enclosure.

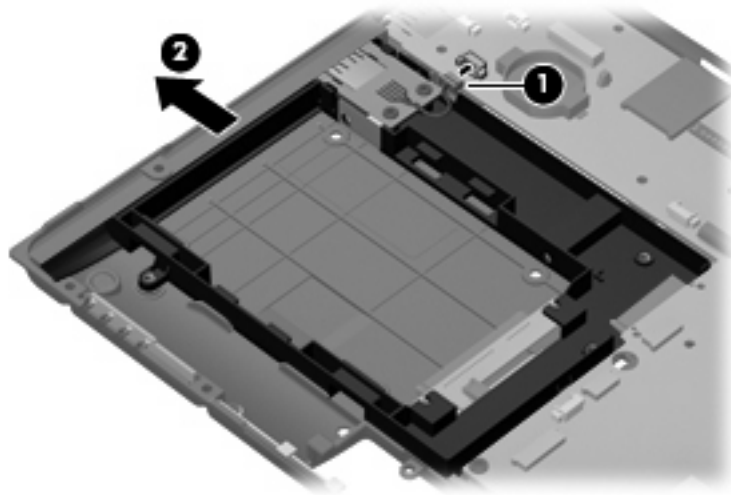

6. Remove the optical drive bezel from the optical drive bay.



7. Remove the two Phillips PM2.0×4.0 screws (1) that secure the USB board to the optical drive bezel.
8. Remove the USB board (2) from the optical drive bezel.

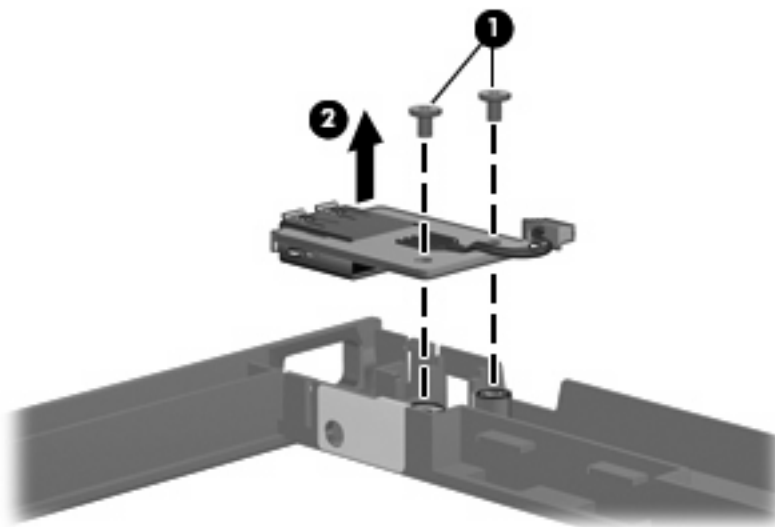

Reverse this procedure to install the USB board and optical drive bezel.

RTC battery

 **NOTE:** Removing the RTC battery and leaving it uninstalled for 5 or more minutes causes all passwords and CMOS settings to be cleared.

Description	Spare part number
RTC battery	481089-001

Before removing the RTC battery, follow these steps:

1. Shut down the computer.
2. Disconnect all external devices connected to the computer.
3. Disconnect the power from the computer by first unplugging the power cord from the AC outlet and then unplugging the AC adapter from the computer.
4. Remove the battery (see [Battery on page 30](#)).
5. Release the switch cover and keyboard (see [Switch cover and keyboard on page 40](#)).

Remove the RTC battery:

- Remove the RTC battery from the socket on the system board.

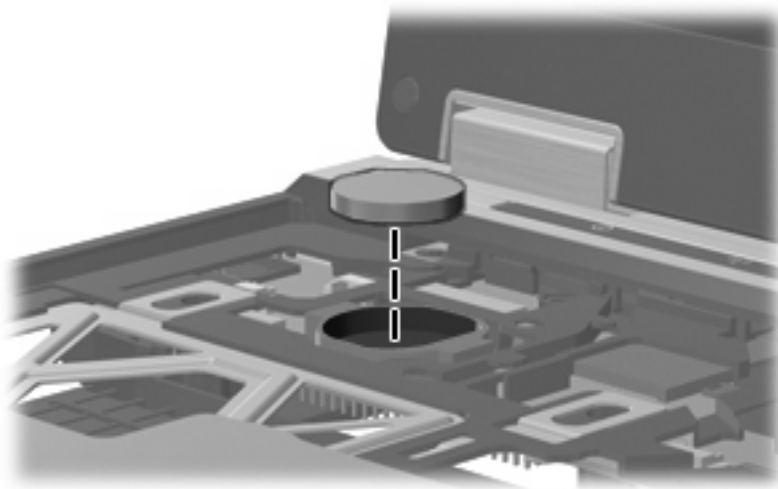

Reverse this procedure to install the RTC battery.

Display assembly

Description	Spare part number
12.1-inch, WXGA AntiGlare display assembly (includes 2 WLAN antenna transceivers and cables and microphones)	481103-001

Before removing the display assembly, follow these steps:

1. Shut down the computer.
2. Disconnect all external devices connected to the computer.
3. Disconnect the power from the computer by first unplugging the power cord from the AC outlet and then unplugging the AC adapter from the computer.
4. Remove the battery (see [Battery on page 30](#)).
5. Disconnect the wireless antenna cables from the WLAN module (see [WLAN module on page 34](#)).
6. Remove the switch cover and keyboard (see [Switch cover and keyboard on page 40](#)).

Remove the display assembly:

1. Close the computer and turn it upside down, with the rear panel toward you.
2. Remove the wireless antenna cables **(1)** from the clips **(2)** built into the base enclosure.

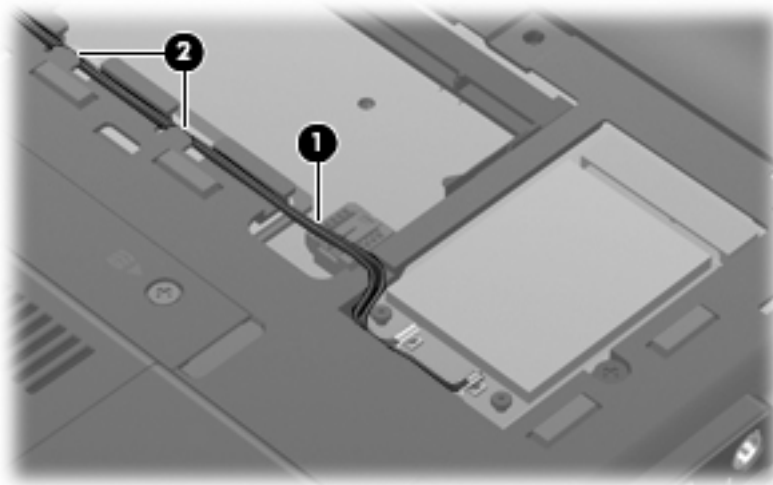

3. Remove the wedge-shaped screw covers (1) and the four Torx T8M2.0×5.0 screws (2) that secure the display assembly to the computer.

 **NOTE:** The rubber screw covers are available in the Rubber Kit, spare part number 481106-001.

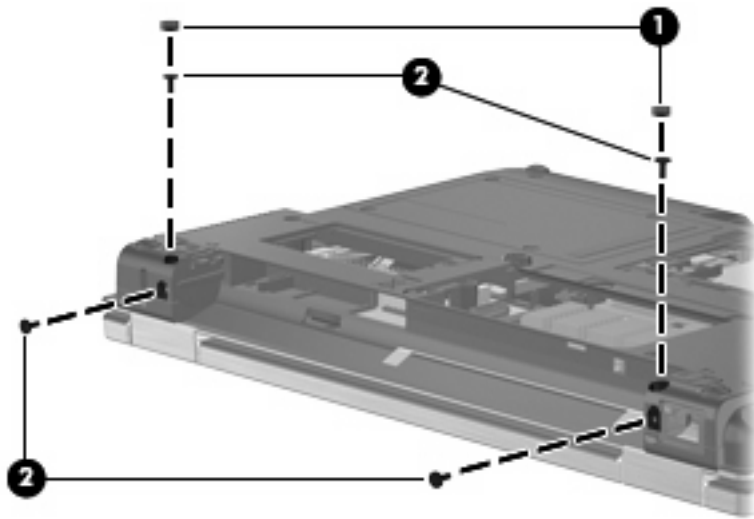

4. Turn the computer right-side up, with the front toward you.
5. Open the computer.
6. Remove the Torx8 T8M2.5×6.0 screw (1) that secures the display panel cable ground loop to the left hinge.
7. Disconnect the display panel cable (2) from the system board.
8. Remove the wireless antenna cables (3) from the clips and routing channels (4) built into the top cover.

9. Disconnect the microphone cable (5) from the system board.

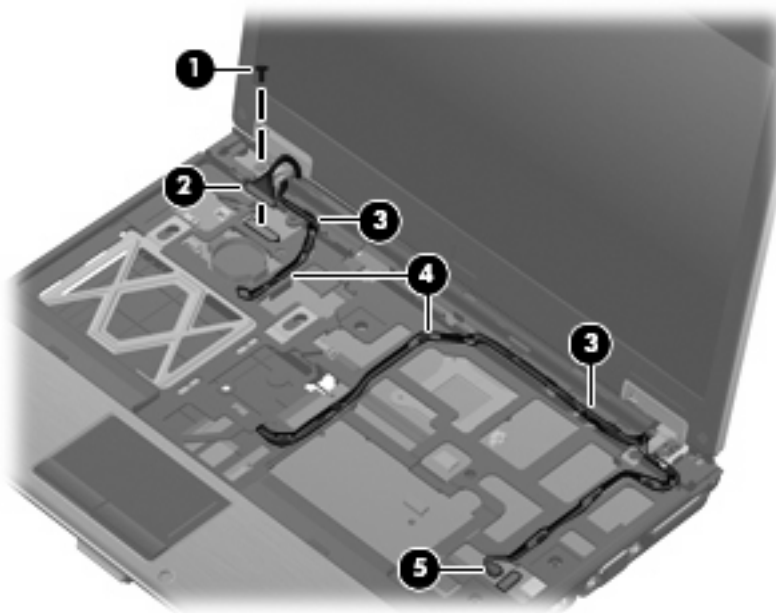

△ **CAUTION:** The display assembly will be unsupported when the following screws are removed. To prevent damage to the display assembly, support it before removing the screws.

10. Remove the T8M2.5×6.0 screw (1) that secures the display assembly to the computer.
11. Lift the display assembly (2) straight up and remove it.

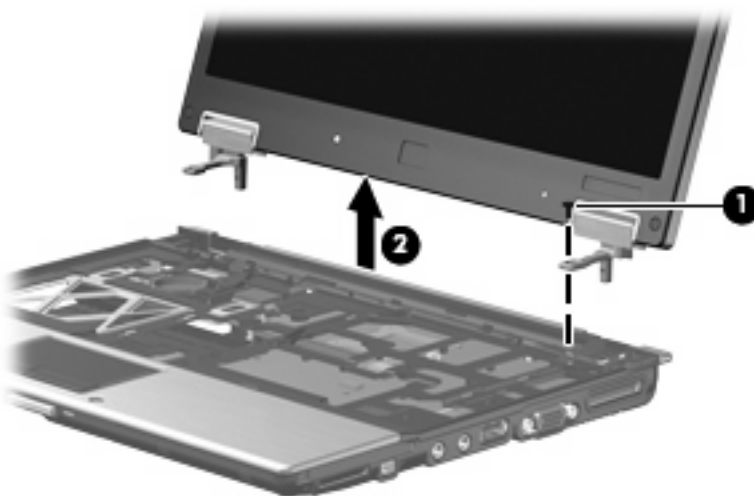

📄 **NOTE:** The display bezel is secured to the display assembly by and by the screws identified in step 12. After the bezel is removed, any residue of the adhesive should be cleaned from the inside edge of the bezel and the display panel metal frame. Then the new adhesive strip material should be put in place.

New adhesive strip material is included in all display bezel, display hinge, display panel cable, and display enclosure spare part kits, and is also available using spare part number 497013-001. This spare part kit includes of two different lengths. The longer are installed on the display bezel and panel top and bottom edges. The shorter are installed on the display bezel and panel left and right edges.

12. If it is necessary to replace the display bezel, display hinges, display panel cable, or display enclosure, remove the four rubber screw covers (1) and (2) and the four Torx T8M2.5×6.0 screws (3) that secure the display bezel to the display assembly.

 **NOTE:** The rubber screw covers (1) on the display bezel top edge are thicker than the rubber screw covers (2) on the display bezel bottom edge. The rubber screw covers are available in the Rubber Kit, spare part number 481106-001.

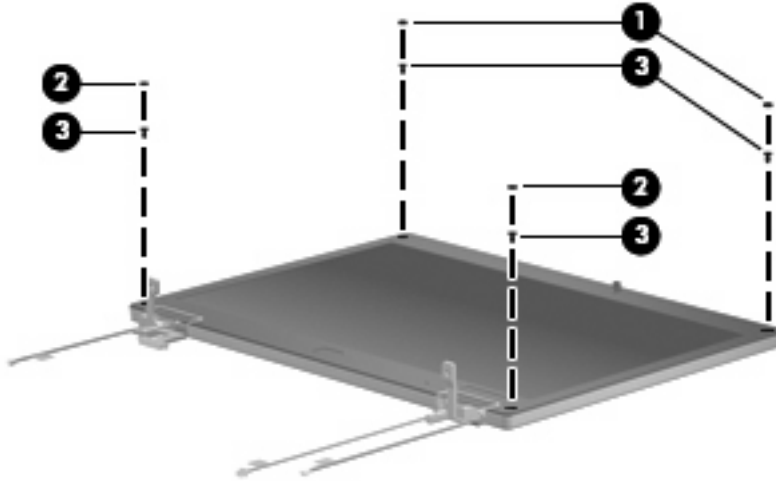

13. Flex the inside edges of the bottom (1), left and right sides (2), and the top (3) of the display bezel until the bezel disengages from the display enclosure.
14. Remove the display bezel (4). The display bezel is available using spare part number 481097-001.

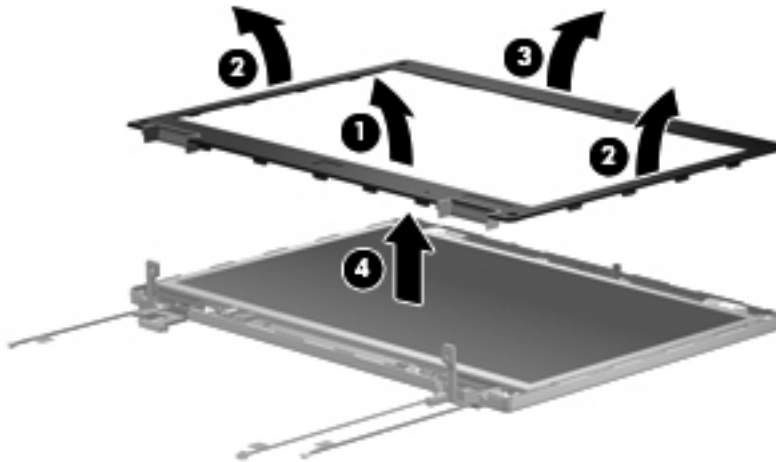

15. If it is necessary to replace the display hinges, remove the two Phillips PM2.5×4.0 screws (1) that secure the display panel to the display enclosure.

16. Remove the display panel (2).

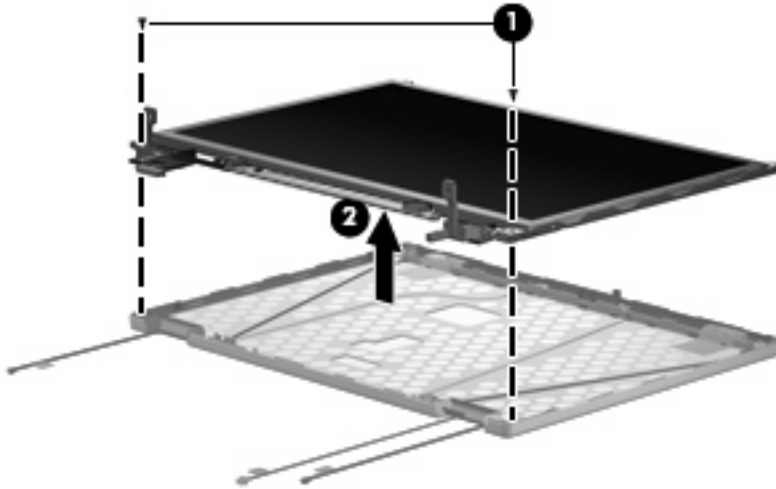

17. Remove the two Phillips PM2.0×4.0 screws (1) that secure each display hinge to the display panel.
18. Remove the display hinges (2). The left and right display hinges are available using spare part number 481098-001.

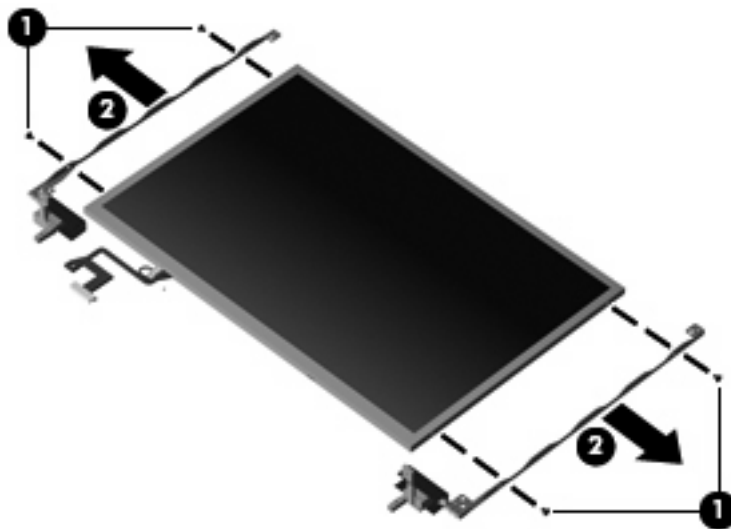

19. If it is necessary to replace the display panel cable, turn the display panel upside down, with the display panel bottom edge toward you.
20. Remove the support tape (1) that secures the top edge of the display panel cable to the display panel.
21. Disconnect the display panel cable (2) from the display panel.
22. Disconnect the display panel cable (3) from the display inverter.

23. Remove the display panel cable (4). The display panel cable is available using spare part number 481099-001.

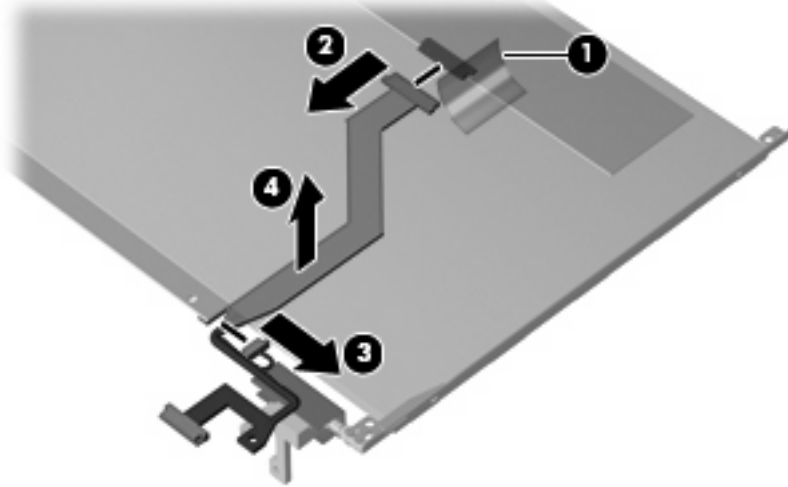

Reverse this procedure to reassemble and install the display assembly.

Top cover

Description	Spare part number
Top cover	481111-001

Before removing the top cover, follow these steps:

1. Shut down the computer.
2. Disconnect all external devices connected to the computer.
3. Disconnect the power from the computer by first unplugging the power cord from the AC outlet and then unplugging the AC adapter from the computer.
4. Remove the battery (see [Battery on page 30](#)).
5. Remove the following components:
 - a. Flash drive (see [Flash drive on page 36](#))
 - b. Optical drive (see [Optical drive on page 38](#))
 - c. Switch cover and keyboard (see [Switch cover and keyboard on page 40](#))
 - d. Display assembly (see [Display assembly on page 47](#))

Remove the top cover:

1. Turn the computer upside down, with the front toward you.
2. Loosen the captive Phillips PM2.5×6.0 screw (1) that secures the Bluetooth module compartment cover to the computer.

3. Lift the front edge of the Bluetooth module compartment cover (2), swing it up and forward, and remove the cover.

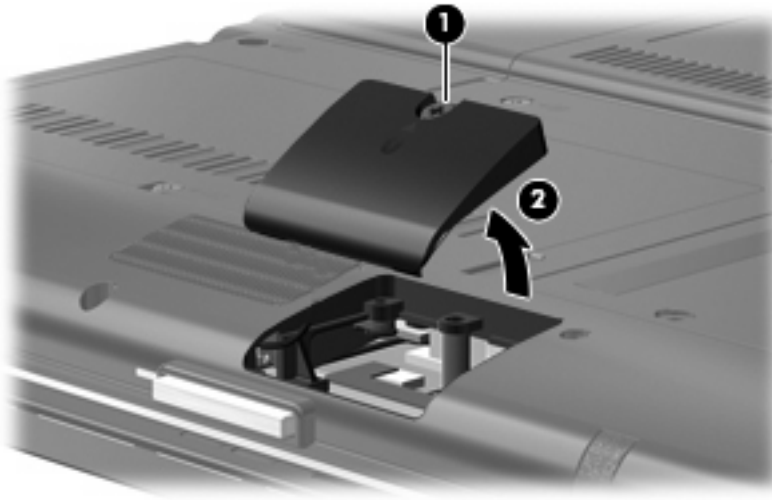

4. Remove the following screw covers and screws:

(1) Four rubber screw covers. The rubber screw covers are included in the Rubber Kit, spare part number 481106-001.

(2) Six Torx T8M2.5×6.0 screws.

(3) One Phillips PM2.0×6.0 screw.

(4) One Torx T8M2.0×5.0 screw.

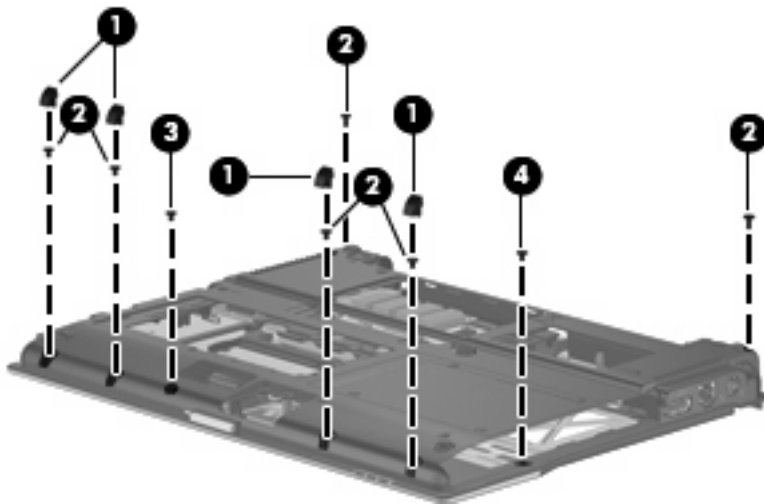

5. Turn the computer right-side up, with the front toward you.
6. Release the ZIF connector to which the TouchPad cable is attached and disconnect the TouchPad cable (1) from the system board.

7. Remove the two Torx T8M2.5×6.0 screws (2) and the Phillips PM2.0×6.0 screw (3) that secure the top cover to the computer.

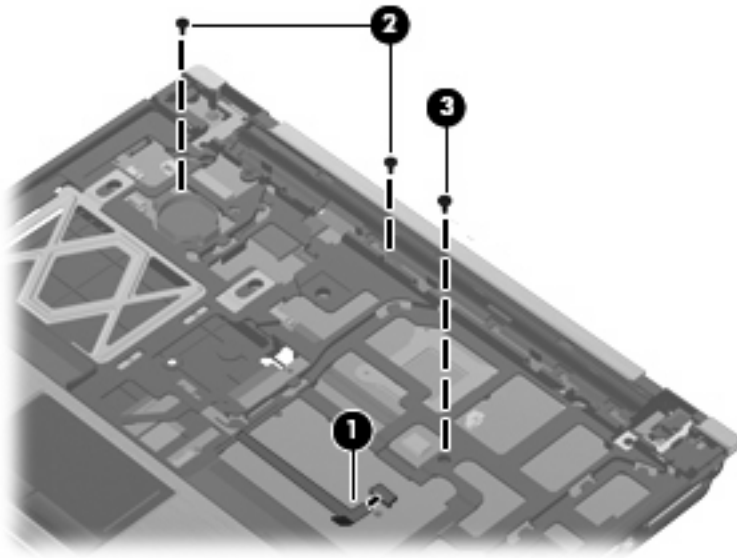

8. Lift the rear edge of the top cover (1) and swing it up and forward until it rests at an angle.
9. Lift the front edge of the top cover (2) until it disengages from the base enclosure.

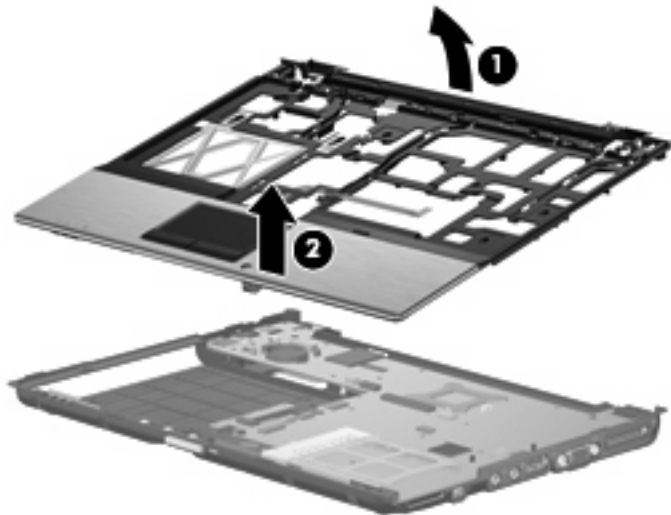

10. Remove the top cover.

Reverse this procedure to install the top cover.

LED board

Description	Spare part number
LED board (includes cable and Mylar cover)	481090-001

Before removing the LED board, follow these steps:

1. Shut down the computer.
2. Disconnect all external devices connected to the computer.
3. Disconnect the power from the computer by first unplugging the power cord from the AC outlet and then unplugging the AC adapter from the computer.
4. Remove the battery (see [Battery on page 30](#)).
5. Remove the following components:
 - a. Flash drive (see [Flash drive on page 36](#))
 - b. Optical drive (see [Optical drive on page 38](#))
 - c. Switch cover and keyboard (see [Switch cover and keyboard on page 40](#))
 - d. Display assembly (see [Display assembly on page 47](#))
 - e. Bluetooth module compartment cover (see [Top cover on page 52](#))
 - f. Top cover (see [Top cover on page 52](#))

Remove the LED board:

1. Release the ZIF connector (1) to which the LED board cable is attached and disconnect the LED board cable (2) from the system board.
2. Remove the LED board (3) from the clip in the base enclosure.

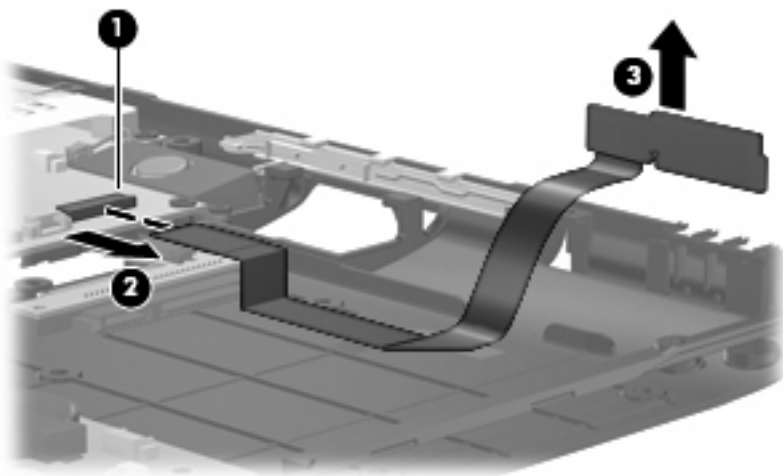

 **NOTE:** The LED board cable is included with the LED board and is also available in the Cables Kit, spare part number 481092-001.

Reverse the above procedure to install the LED board.

Speaker

Description	Spare part number
Speaker	481109-001

Before removing the speaker, follow these steps:

1. Shut down the computer.
2. Disconnect all external devices connected to the computer.
3. Disconnect the power from the computer by first unplugging the power cord from the AC outlet and then unplugging the AC adapter from the computer.
4. Remove the battery (see [Battery on page 30](#)).
5. Remove the following components:
 - a. Flash drive (see [Flash drive on page 36](#))
 - b. Optical drive (see [Optical drive on page 38](#))
 - c. Switch cover and keyboard (see [Switch cover and keyboard on page 40](#))
 - d. Display assembly (see [Display assembly on page 47](#))
 - e. Top cover (see [Top cover on page 52](#))

Remove the speaker:

1. Disconnect the speaker cable (1) from the system board.
2. Remove the Phillips PM2.0×4.0 screw (2) that secures the speaker to the base enclosure.
3. Remove the speaker (3) from the base enclosure.

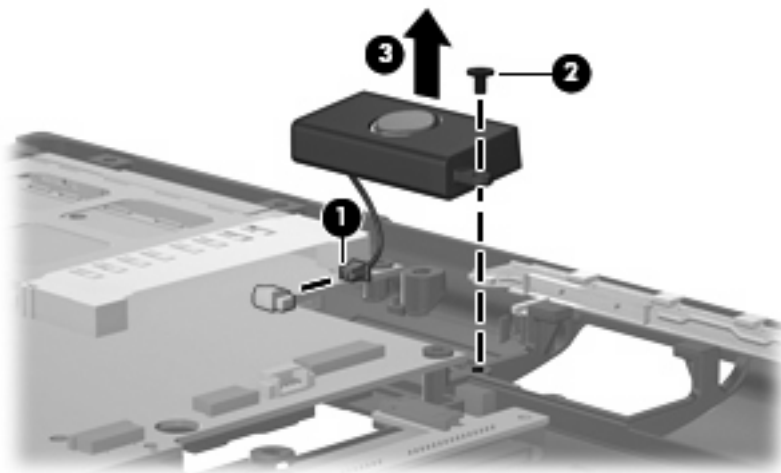

Reverse this procedure to install the speaker.

System board

Description	Spare part number
System board (includes processor, replacement thermal material, and replacement thermal material cleaning kit)	481091-001

Before removing the system board, follow these steps:

1. Shut down the computer.
2. Disconnect all external devices connected to the computer.
3. Disconnect the power from the computer by first unplugging the power cord from the AC outlet and then unplugging the AC adapter from the computer.
4. Remove the battery (see [Battery on page 30](#)).
5. Remove the following components:
 - a. Flash drive (see [Flash drive on page 36](#))
 - b. WLAN module (see [WLAN module on page 34](#))
 - c. Optical drive (see [Optical drive on page 38](#))
 - d. Switch cover and keyboard (see [Switch cover and keyboard on page 40](#))
 - e. Display assembly (see [Display assembly on page 47](#))
 - f. Top cover (see [Top cover on page 52](#))

When replacing the system board, be sure that the following components are removed from the defective system board and installed on the replacement system board:

- Memory module (see [Memory module on page 32](#))
- Flash drive (see [Flash drive on page 36](#))
- Heat sink (see [Heat sink on page 63](#))
- WLAN module (see [WLAN module on page 34](#))

Remove the system board:

1. Release the ZIF connector to which the front LED board cable is attached and disconnect the front LED board cable **(1)** from the system board.
2. Disconnect the speaker cable **(2)** from the system board.

3. Remove the three Torx8 T8M2.5×6.0 screws (3) that secure the system board to the base enclosure.

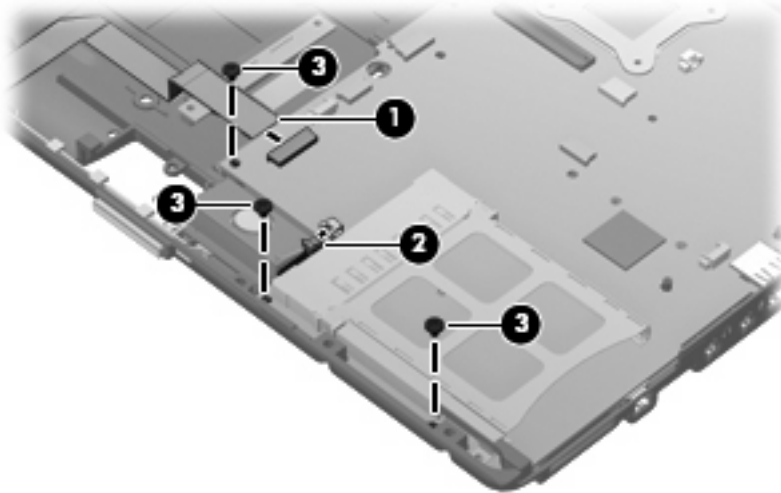

4. Flex the left side of the base enclosure (1) until the RJ-11 jack and USB ports are clear of the openings in the base enclosure.
5. Use the optical drive connector (2) to lift the left side of the system board (3) until it rests at an angle.
6. Remove the system board (4) from the base enclosure by sliding it up and to the left.

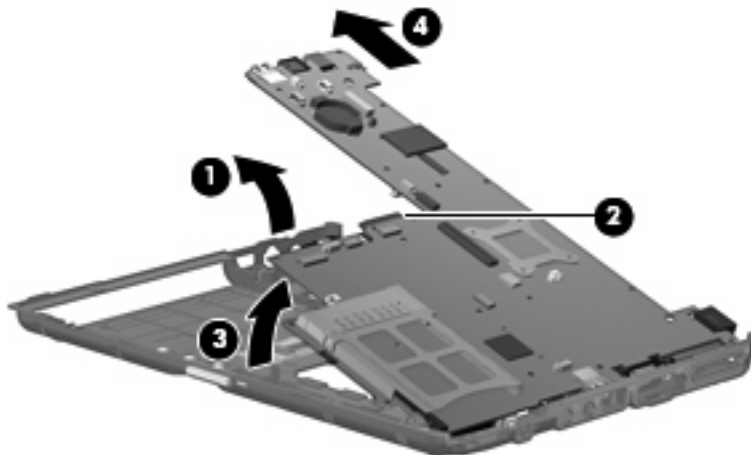

Reverse the preceding procedure to install the system board.

PC Card assembly

Description	Spare part number
PC Card assembly	481104-001

Before removing the PC Card assembly, follow these steps:

1. Shut down the computer.
2. Disconnect all external devices connected to the computer.
3. Disconnect the power from the computer by first unplugging the power cord from the AC outlet and then unplugging the AC adapter from the computer.
4. Remove the battery (see [Battery on page 30](#)).
5. Remove the following components:
 - a. Flash drive (see [Flash drive on page 36](#))
 - b. WLAN module (see [WLAN module on page 34](#))
 - c. Optical drive (see [Optical drive on page 38](#))
 - d. Switch cover and keyboard (see [Switch cover and keyboard on page 40](#))
 - e. Display assembly (see [Display assembly on page 47](#))
 - f. Top cover (see [Top cover on page 52](#))
 - g. System board (see [System board on page 57](#))

Remove the PC Card assembly:

1. Turn the system board upside down, with the front toward you.
2. Remove the two Phillips PM2.0×5.0 screws that secure the PC Card assembly to the system board.

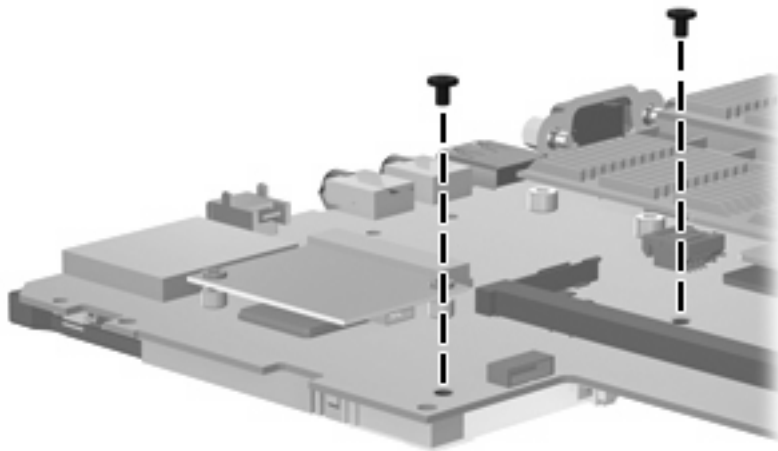

3. Turn the system board upside down, with the rear toward you.

4. Detach the slot (1) on the PC Card assembly from the tab on the PC Card assembly connector on the system board.
5. Remove the PC Card assembly (2).

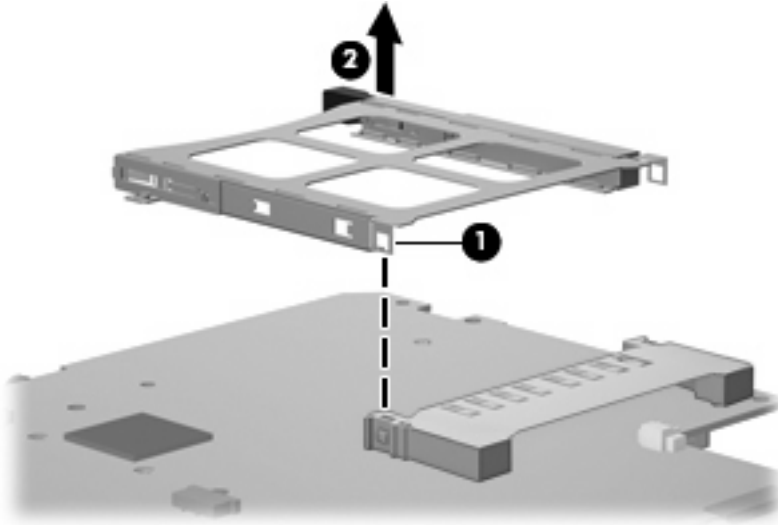

Reverse this procedure to install the PC Card assembly.

Modem module

 **NOTE:** The modem module spare part kits do not include a modem module cable. The modem module cable is included in the Cable Kit, spare part number 481092-001. See [Cable Kit on page 20](#) for more Cable Kit spare part number information.

Description	Spare part number
For use in all countries and regions except Australia and New Zealand	461750-001
For use only in Australia and New Zealand	461750-002

Before removing the modem module, follow these steps:

1. Shut down the computer.
2. Disconnect all external devices connected to the computer.
3. Disconnect the power from the computer by first unplugging the power cord from the AC outlet and then unplugging the AC adapter from the computer.
4. Remove the battery (see [Battery on page 30](#)).
5. Remove the following components:
 - a. Flash drive (see [Flash drive on page 36](#))
 - b. WLAN module (see [WLAN module on page 34](#))
 - c. Optical drive (see [Optical drive on page 38](#))
 - d. Switch cover and keyboard (see [Switch cover and keyboard on page 40](#))
 - e. Display assembly (see [Display assembly on page 47](#))
 - f. Top cover (see [Top cover on page 52](#))
 - g. System board (see [System board on page 57](#))

Remove the modem module:

1. Turn the system board upside down, with the front toward you.
2. Remove the two Phillips PM2.0×4.0 screws **(1)** that secure the modem module to the system board.
3. Lift the modem module **(2)** straight up until it disconnects from the system board.

4. Disconnect the modem module cable (3) from the modem module.

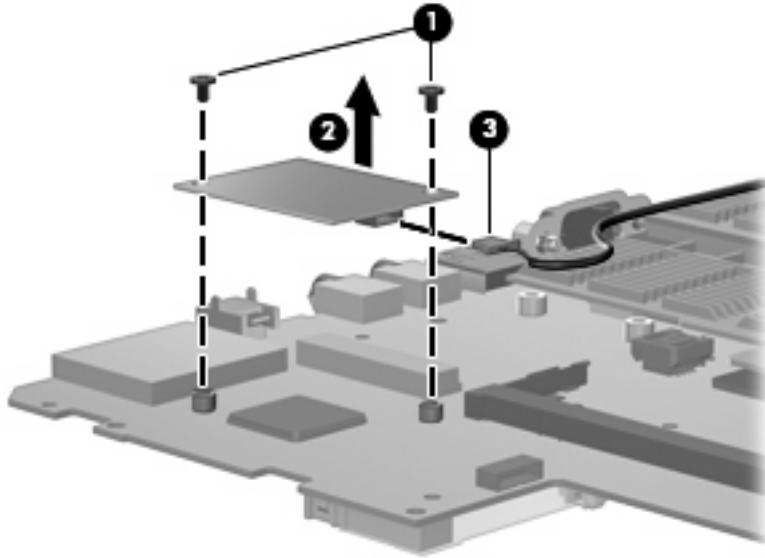

5. Remove the modem module.

Reverse this procedure to install the modem module.

Heat sink

Description	Spare part number
Heat sink (includes replacement thermal material and replacement thermal material cleaning kit)	481110-001

Before removing the heat sink, follow these steps:

1. Shut down the computer.
2. Disconnect all external devices connected to the computer.
3. Disconnect the power from the computer by first unplugging the power cord from the AC outlet and then unplugging the AC adapter from the computer.
4. Remove the battery (see [Battery on page 30](#)).
5. Remove the following components:
 - a. Flash drive (see [Flash drive on page 36](#))
 - b. WLAN module (see [WLAN module on page 34](#))
 - c. Optical drive (see [Optical drive on page 38](#))
 - d. Switch cover and keyboard (see [Switch cover and keyboard on page 40](#))
 - e. Display assembly (see [Display assembly on page 47](#))
 - f. Top cover (see [Top cover on page 52](#))
 - g. System board (see [System board on page 57](#))

Remove the heat sink:

1. Turn the system board upside down, with the front toward you.
2. Following the 1, 2, 3, 4 sequence stamped into the heat sink, loosen the four Torx8 T8M2.0×10.0 screws (**1**) that secure the heat sink to the system board.

3. Remove the heat sink (2).

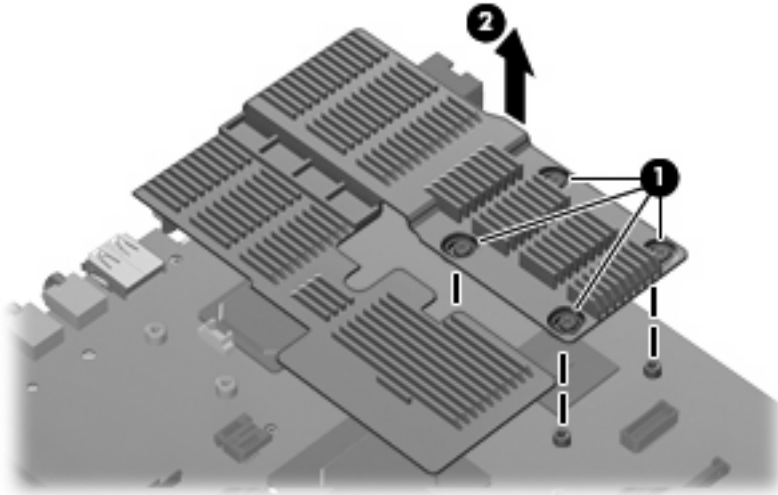

 **NOTE:** The thermal material must be thoroughly cleaned from the surfaces of the heat sink and system board each time the heat sink is removed. Thermal paste is located on the processor (1) and the section of the heat sink that services it (2). Thermal pads are located on the Northbridge chip (3) and the section of the heat sink that services it (4). Replacement thermal material is included with all heat sink and system board spare part kits.

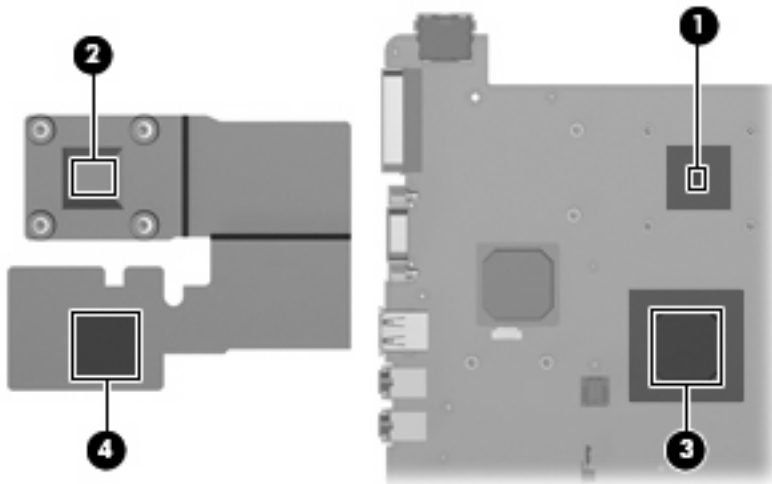

Reverse this procedure to install the heat sink.

5 Computer Setup

Starting Computer Setup

Computer Setup is a preinstalled ROM-based utility that can be used even when the operating system is not working or will not load.

 **NOTE:** Some of the Computer Setup menu items listed in this guide may not be supported by your computer.

NOTE: Pointing devices are not supported in Computer Setup. You must use the keyboard to navigate and make selections.

To start Computer Setup, follow these steps:

1. Turn on or restart the computer.
2. Before Windows opens and while the “F10=ROM Based Setup” message is displayed in the lower-left corner of the screen, press **f10**.

Using Computer Setup

Navigating and selecting in Computer Setup

The information and settings in Computer Setup are accessed from the File, Security, Diagnostics, and System Configuration menus.

1. Open Computer Setup by turning on or restarting the computer, and then pressing **f10** while the "F10 = ROM Based Setup" message is displayed in the lower-left corner of the screen.

Because Computer Setup is not Windows-based, it does not support the TouchPad. Navigation and selection are by keystroke:

- To choose a menu or a menu item, use the arrow keys.
 - To select an item, press **enter**.
 - To close open dialog boxes and return to the main Computer Setup screen, press **esc**.
 - To view navigation information, press **f1**.
 - To change the language, press **f2**.
2. Select the **File**, **Security**, **Diagnostics**, or **System Configuration** menu.
 3. To exit Computer Setup, choose one of the following methods:
 - To exit Computer Setup without saving your preferences, use the arrow keys to select **File > Ignore Changes and Exit**. Then follow the instructions on the screen.
 - To save your preferences and exit Computer Setup, use the arrow keys to select **File > Save Changes and Exit**. Then follow the instructions on the screen.

Your preferences go into effect when the computer restarts.

Restoring factory settings in Computer Setup

To return all settings in Computer Setup to the values that were set at the factory, follow these steps:

1. Open Computer Setup by turning on or restarting the computer, and then pressing **f10** while the "F10 = ROM Based Setup" message is displayed in the lower-left corner of the screen.
2. Use the arrow keys to select **File > Restore** defaults, and then press **enter**.
3. When the confirmation dialog box opens, press **f10**.
4. To save your preferences and exit Computer Setup, use the arrow keys to select **File > Save Changes and Exit**. Then follow the instructions on the screen.

Your preferences go into effect when the computer restarts.

 **NOTE:** Your password settings and security settings are not changed when you restore the factory settings.

Computer Setup menus

The menu tables in this section provide an overview of Computer Setup options.

 **NOTE:** Some of the Computer Setup menu items listed in this chapter may not be supported by your computer.

File menu

Select	To do this
System information	<ul style="list-style-type: none">• View identification information for the computer and the batteries in the system.• View specification information for the processor, cache and memory size, system ROM, video revision, and keyboard controller version.
Restore defaults	Replace the configuration settings in Computer Setup with the original factory settings. (Password settings and security settings are not changed when you restore the factory settings.)
Ignore changes and exit	Cancel any changes entered during the current session. Then exit and restart the computer.
Save changes and exit	Save any changes entered during the current session. Then exit and restart the computer. Your changes go into effect when the computer restarts.

Security menu

Select	To do this
Setup Password	Enter, change, or delete a setup password.
Power-On Password	Enter, change, or delete a power-on password.
Password Options	<ul style="list-style-type: none">• Enable/disable stringent security.• Enable/disable password requirement on computer restart.
System IDs	Enter user-defined computer asset tracking number and ownership tag.

Diagnostics menu

Select	To do this
Memory Check	Run a comprehensive check on system memory.

System Configuration menu

 **NOTE:** Some of the listed System Configuration options may not be supported by your computer.

Select	To do this
Language (or press f2)	Change the Computer Setup language.
Boot options	<ul style="list-style-type: none">• Set f9, f10, and f12 delay when starting up.• Enable/disable CD-ROM boot.• Enable/disable floppy boot.• Enable/disable internal network adapter boot.• Enable/disable MultiBoot, which sets a boot order that can include most boot devices in the system.• Set the boot order.
Device configurations	<ul style="list-style-type: none">• Swap the functions of the fn key and left ctrl key.• Enable/disable USB legacy support. When enabled, USB legacy support allows the following:<ul style="list-style-type: none">◦ Use of a USB keyboard in Computer Setup even when a Windows operating system is not running.◦ Startup from bootable USB devices, including a hard drive, diskette drive, or optical drive connected by a USB port to the computer.
Built-In Device Options	<ul style="list-style-type: none">• Enable/disable embedded WLAN Device Radio.• Enable/disable network Interface Controller (LAN)• Enable/disable LAN/WAN switching.• Enable/disable Wake on LAN.• Enable/disable the optical disc drive.
Port Options	<ul style="list-style-type: none">• Enable/disable the USB port.• Enable/disable the PC Card slot.• Enable/disable flash media reader.

6 Specifications

Computer specifications

	Metric	U.S.
Dimensions		
Depth	21.43 cm	8.44 in
Width	28.23 cm	11.11 in
Height (front to rear)	2.52 to 3.40 cm	0.99 to 1.34 in
Weight		
Equipped with DVD-ROM Drive, 9-cell battery, and WLAN module	1.79 kg	3.95 lbs
Equipped with DVD-ROM Drive, 6-cell battery, and WLAN module	1.64 kg	3.62 lbs
Equipped with DVD-ROM Drive, 3-cell battery, and WLAN module	1.48 kg	3.26 lbs
Equipped with 3-cell battery and WLAN module	1.29 kg	2.84 lbs
Input power		
Operating voltage	18.5 V dc @ 3.50 A – 65 W	
Operating current	3.50 A	
Temperature		
Operating (reading to optical disc)	0°C to 35°C	32°F to 95°F
Nonoperating	-20°C to 60°C	-4°F to 140°F
Relative humidity (noncondensing)		
Operating	10% to 90%	
Nonoperating	5% to 95%	
Maximum altitude (unpressurized)		
Operating (14.7 to 10.1 psia)	-15 m to 3,048 m	-50 ft to 10,000 ft
Nonoperating (14.7 to 4.4 psia)	-15 m to 12,192 m	-50 ft to 40,000 ft
Shock		
Operating	125 g, 2 ms, half-sine	

	Metric	U.S.
Nonoperating	200 g, 2 ms, half-sine	
Random vibration		
Operating	0.75 g zero-to-peak, 10 Hz to 500 Hz, 0.25 oct/min sweep rate	
Nonoperating	1.50 g zero-to-peak, 10 Hz to 500 Hz, 0.5 oct/min sweep rate	
NOTE: Applicable product safety standards specify thermal limits for plastic surfaces. The computer operates well within this range of temperatures.		

12.1-inch, WXGA display specifications

	Metric	U.S.
Dimensions		
Height	16.9 cm	6.7 in
Width	26.2 cm	10.3 in
Diagonal	30.8 cm	12.1 in
Number of colors	Up to 16.8 million	
Contrast ratio	250:1 (typical)	
Brightness	180 nits (typical)	
Pixel resolution		
Pitch	0.279 × 0.279 mm	
Format	1280 × 800	
Configuration	RGB vertical stripe	
Backlight	Edge lit	
Character display	80 × 25	
Total power consumption	4.0 W	
Viewing angle	+/-40 horizontal, +20/-40° vertical (typical)	

8X Max DVD-ROM Drive specifications

Applicable disc	DVD-ROM (DVD-5, DVD-9, DVD-10, DVD-18), CD-ROM (Mode 1 and 2), CD Digital Audio, CD-XA ready (Mode 2, Form 1 and Form 2), CD-I (Mode 2, Form 1 and Form 2), CD-RW, Photo CD (single and multisession), and CD-Bridge	
Access time	CD	DVD
Random	< 100 ms	< 125 ms
Cache buffer	512 KB	
Data transfer rate		
CD-R (24X)	3,600 KB/sec (150 KB/s at 1X CD rate)	
CD-RW (10X)	1,500 KB/sec (150 KB/s at 1X CD rate)	
CD-ROM (24X)	3,600 KB/sec (150 KB/s at 1X CD rate)	
DVD (8X)	10,800 KB/sec (1,352 KB/s at 1X DVD rate)	
Multiword DMA mode 2	16.6 MB/sec	

System DMA specifications

Hardware DMA	System function
DMA0	Not applicable
DMA1*	Not applicable
DMA2*	Not applicable
DMA3	Not applicable
DMA4	Direct memory access controller
DMA5*	Available for ExpressCard
DMA6	Not assigned
DMA7	Not assigned

*ExpressCard controller can use DMA 1, 2, or 5.

System interrupt specifications

Hardware IRQ	System function
IRQ0	System timer
IRQ1	Standard 101-/102-Key or Microsoft® Natural Keyboard
IRQ2	Cascaded
IRQ3	Intel 82801DB/DBM USB2 Enhanced Host Controller—24CD
IRQ4	COM1
IRQ5*	Conexant AC—Link Audio Intel 82801DB/DBM SMBus Controller—24C3 Data Fax Modem with SmartCP
IRQ6	Diskette drive
IRQ7*	Parallel port
IRQ8	System CMOS/real-time clock
IRQ9*	Microsoft ACPI-compliant system
IRQ10*	Intel USB UHCI controller—24C2 Intel 82852/82855 GM/GME Graphic Controller Realtek RTL8139 Family PCI Fast Ethernet Controller
IRQ11	Intel USB EHCI controller—24CD Intel USB UHCI controller—24C4 Intel USB UHCI controller—24C7 Intel Pro/Wireless 2200BG TI OHCI 1394 host controller TI PCI1410 CardBus controller
IRQ12	Synaptics PS/2 TouchPad
IRQ13	Numeric data processor
IRQ14	Primary IDE channel
IRQ15	Secondary IDE channel

*Default configuration; audio possible configurations are IRQ5, IRQ7, IRQ9, IRQ10, or none.

NOTE: ExpressCards may assert IRQ3, IRQ4, IRQ5, IRQ7, IRQ9, IRQ10, IRQ11, or IRQ15. Either the infrared or the serial port may assert IRQ3 or IRQ4.

System I/O address specifications

I/O address (hex)	System function (shipping configuration)
000 - 00F	DMA controller no. 1
010 - 01F	Unused
020 - 021	Interrupt controller no. 1
022 - 024	Opti chipset configuration registers
025 - 03F	Unused
02E - 02F	87334 "Super I/O" configuration for CPU
040 - 05F	Counter/timer registers
044 - 05F	Unused
060	Keyboard controller
061	Port B
062 - 063	Unused
064	Keyboard controller
065 - 06F	Unused
070 - 071	NMI enable/RTC
072 - 07F	Unused
080 - 08F	DMA page registers
090 - 091	Unused
092	Port A
093 - 09F	Unused
0A0 - 0A1	Interrupt controller no. 2
I/O Address (hex)	System Function (shipping configuration)
0A2 - 0BF	Unused
0C0 - 0DF	DMA controller no. 2
0E0 - 0EF	Unused
0F0 - 0F1	Coprocessor busy clear/reset
0F2 - 0FF	Unused
100 - 16F	Unused
170 - 177	Secondary fixed disk controller
178 - 1EF	Unused
1F0 - 1F7	Primary fixed disk controller
1F8 - 200	Unused
201	Joystick (decoded in ESS1688)
202 - 21F	Unused

I/O address (hex)	System function (shipping configuration)
220 - 22F	Entertainment audio
230 - 26D	Unused
26E - 26	Unused
278 - 27F	Unused
280 - 2AB	Unused
2A0 - 2A7	Unused
2A8 - 2E7	Unused
2E8 - 2EF	Reserved serial port
2F0 - 2F7	Unused
2F8 - 2FF	Infrared port
300 - 31F	Unused
320 - 36F	Unused
370 - 377	Secondary diskette drive controller
378 - 37F	Parallel port (LPT1/default)
380 - 387	Unused
388 - 38B	FM synthesizer—OPL3
38C - 3AF	Unused
3B0 - 3BB	VGA
3BC - 3BF	Reserved (parallel port/no EPP support)
3C0 - 3DF	VGA
3E0 - 3E1	ExpressCard controller in CPU
3E2 - 3E3	Unused
3E8 - 3EF	Internal modem
3F0 - 3F7	“A” diskette controller
3F8 - 3FF	Serial port (COM1/default)
CF8 - CFB	PCI configuration index register (PCIDIVO-1)
CFC - CFF	PCI configuration data register (PCIDIVO-1)

System memory map specifications

Size	Memory address	System function
640 KB	00000000-0009FFFF	Base memory
128 KB	000A0000-000BFFFF	Video memory
48 KB	000C0000-000CBFFF	Video BIOS
160 KB	000C8000-000E7FFF	Unused
64 KB	000E8000-000FFFFFF	System BIOS
15 MB	00100000-00FFFFFF	Extended memory
58 MB	04800000-07FFFFFF	Super extended memory
58 MB	04800000-07FFFFFF	Unused
2 MB	08000000-08FFFFFF	Video memory (direct access)
4 GB	08200000-FFFFFF	Unused
64 KB	FFFF0000-FFFFFFFF	System BIOS

7 Screw listing

This section provides specification and reference information for the screws and screw locks used in the computer. All screws listed in this section are available in the Screw Kit, spare part number 456615-001.

Phillips PM2.5×6.0 captive screw

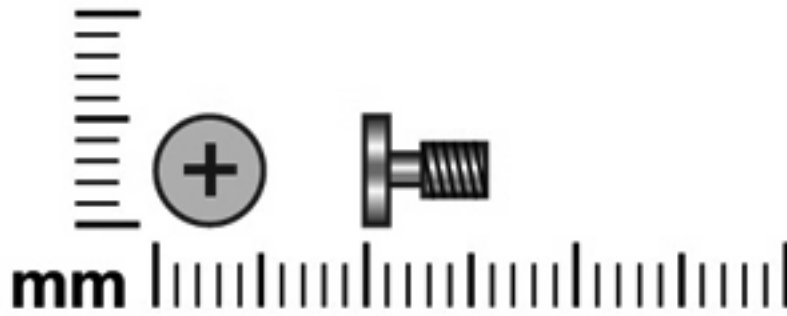

Color	Quantity	Length	Thread	Head diameter
Black	5	6.0 mm	2.5 mm	5.0 mm

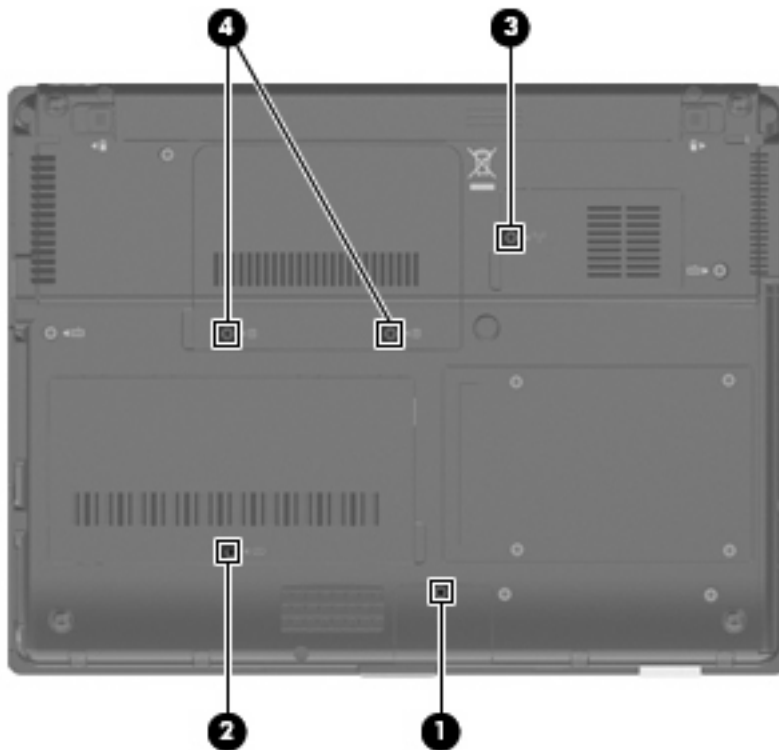

Where used:

- (1) One captive screw that secures the Bluetooth module cover to the computer (screw is captured on the cover by a C-clip)
- (2) One captive screw that secures the memory module compartment cover to the computer (screw is captured on the cover by a C-clip)
- (3) One captive screw that secures the flash drive compartment cover to the computer (screw is captured on the cover by a C-clip)
- (4) Two captive screws that secure the rear cover to the computer (screws are secured by C-clips)

Phillips PM2.0×4.0 screw

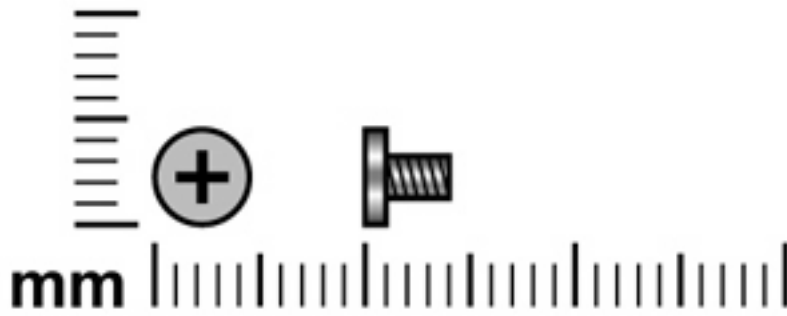

Color	Quantity	Length	Thread	Head diameter
Silver	15	4.0 mm	2.0 mm	4.5 mm

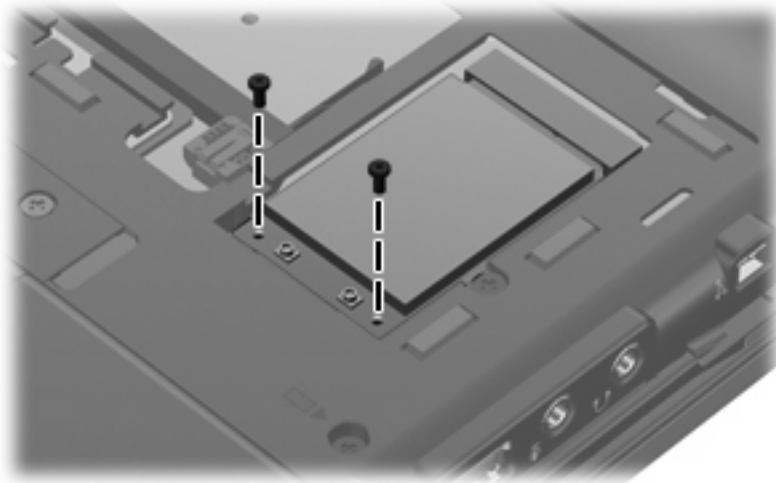

Where used: 2 screws that secure the WLAN module to the base enclosure

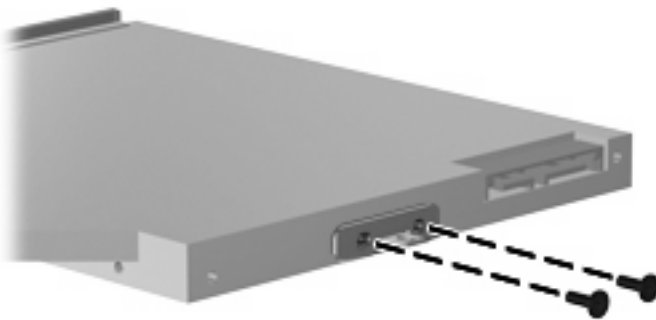

Where used: 2 screws that secure the optical drive bracket to the optical drive

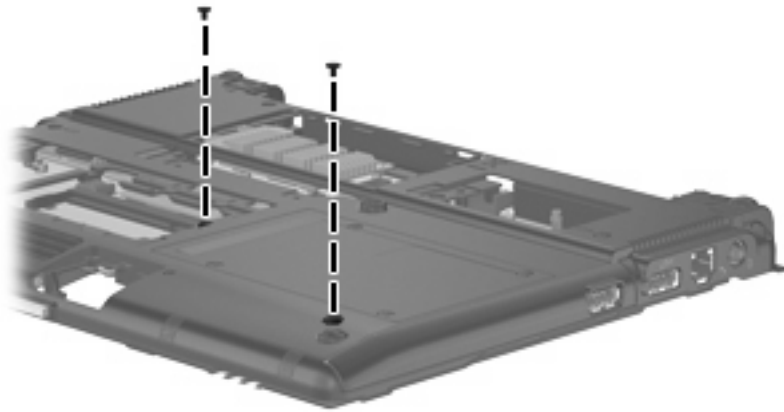

Where used: 2 screws that secure the optical drive bezel to the computer

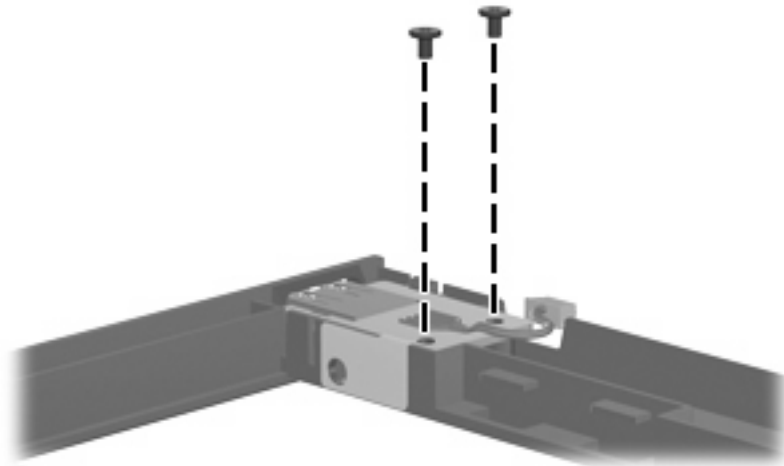

Where used: 2 screws that secure the USB board to the optical drive bezel

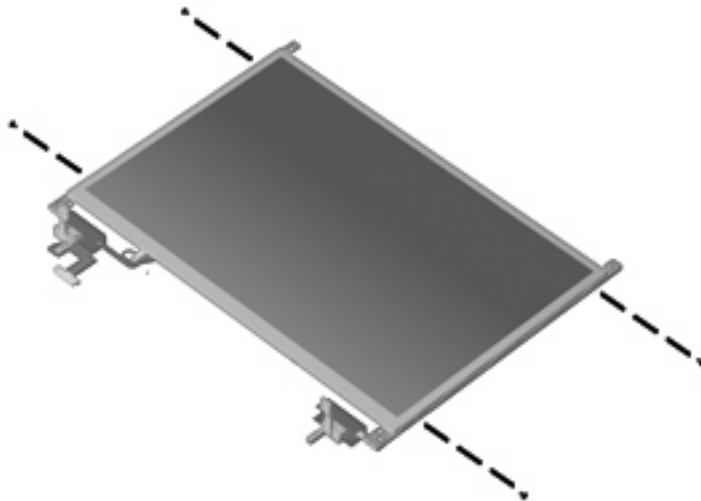

Where used: 4 screws that secure the display hinges to the display panel

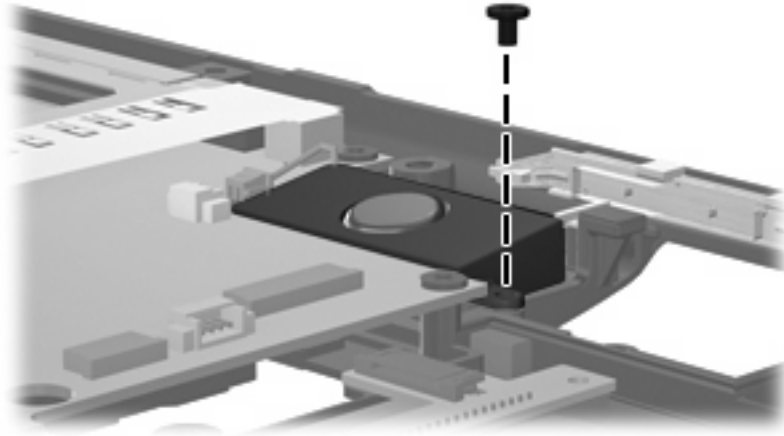

Where used: One screw that secures the speaker to the base enclosure

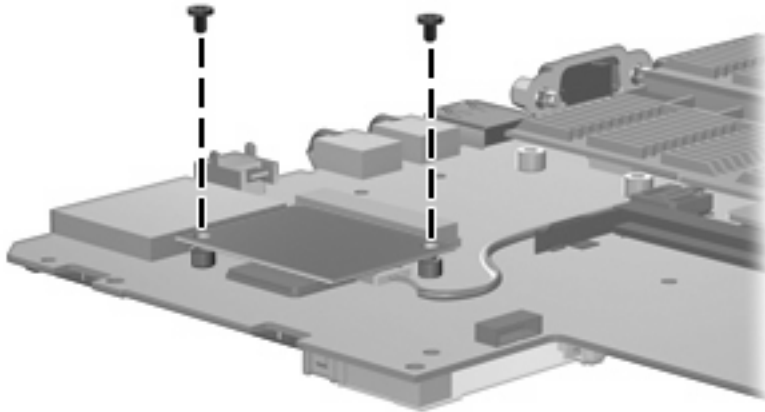

Where used: 2 screws that secure the modem module to the system board

Torx T8M2.0×5.0 screw

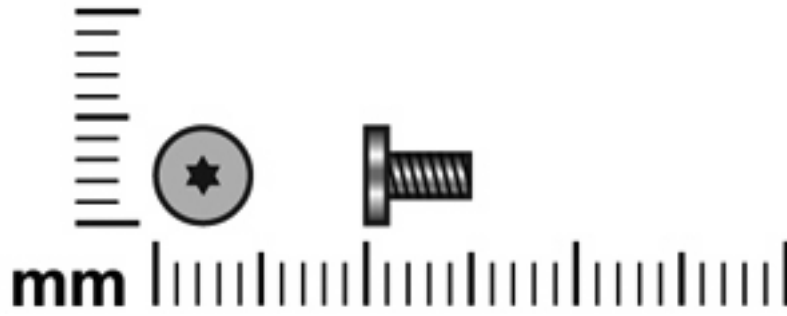

Color	Quantity	Length	Thread	Head diameter
Black	7	5.0 mm	2.0 mm	4.5 mm

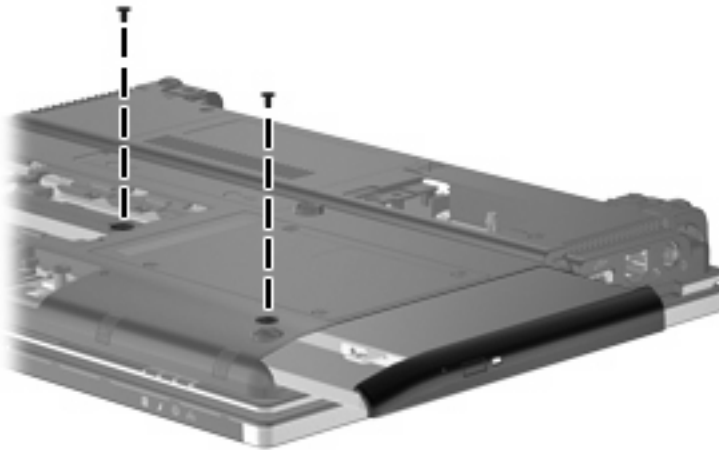

Where used: 2 screws that secure the optical drive to the computer

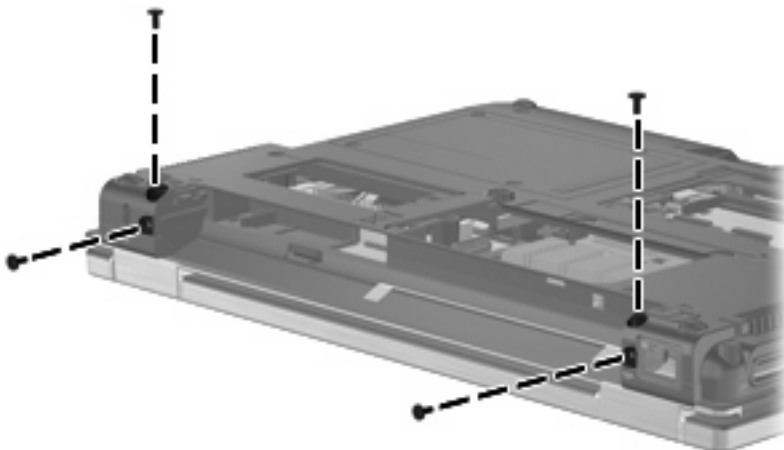

Where used: 4 screws that secure the display assembly to the computer

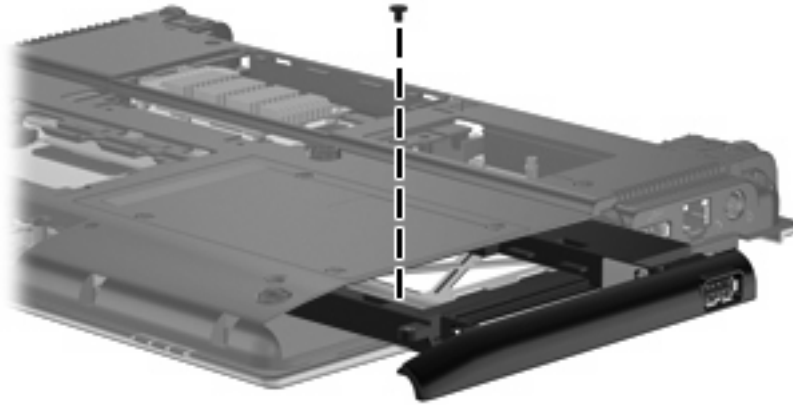

Where used: One screw that secures the top cover to the base enclosure

Torx T8M2.5×6.0 screw

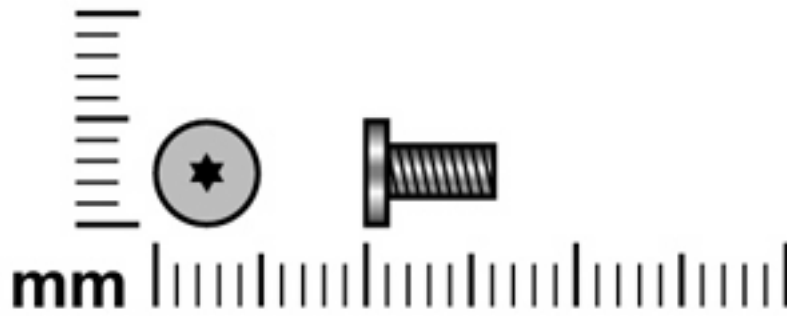

Color	Quantity	Length	Thread	Head diameter
Black	18	6.0 mm	2.5 mm	5.0 mm

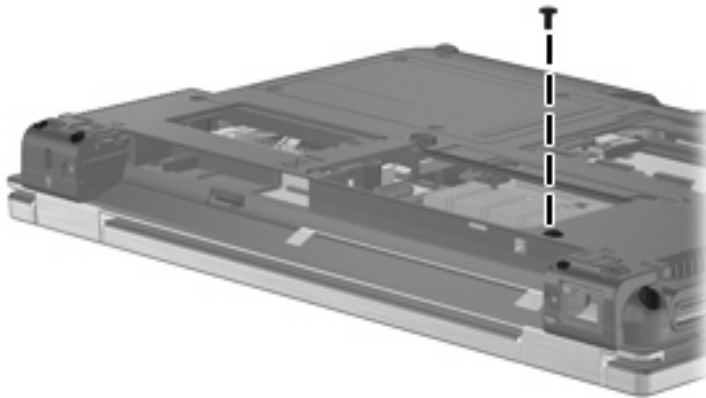

Where used: One screw that secures the switch cover to the computer



Where used: 2 screws that secure the display assembly to the computer

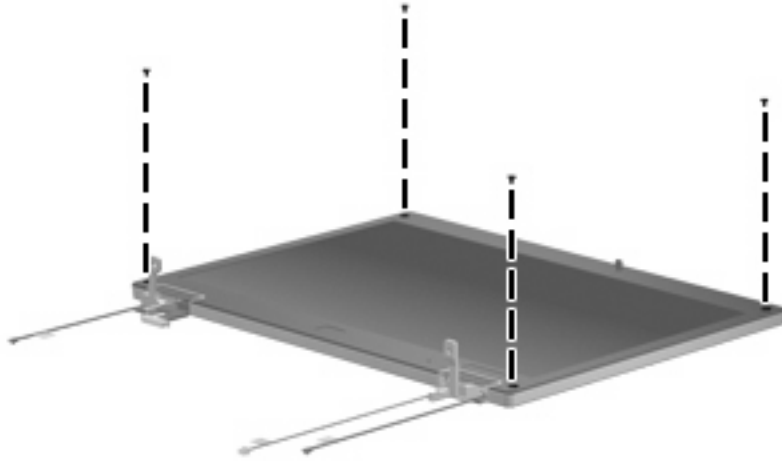

Where used: 4 screws that secure the display bezel to the display enclosure

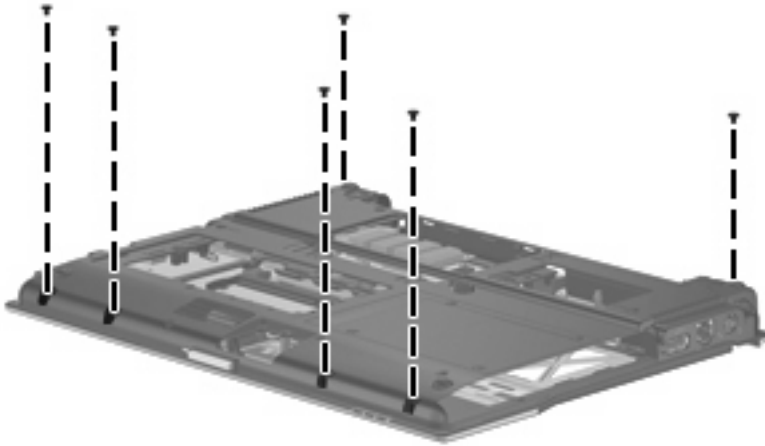

Where used: 6 screws that secure the top cover to the base enclosure

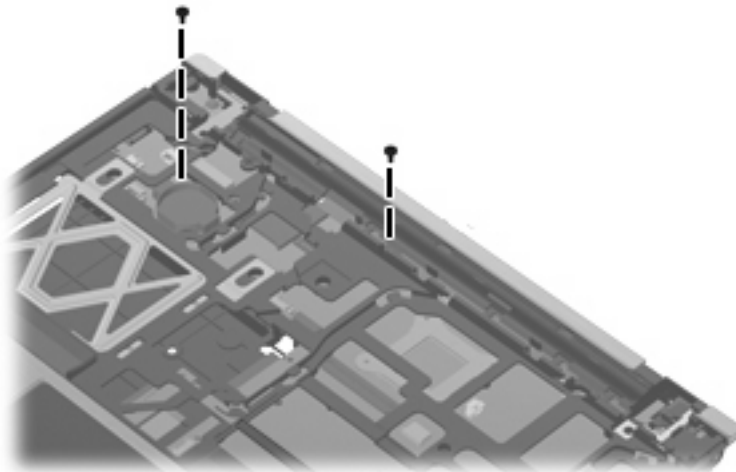

Where used: 2 screws that secure the top cover to the base enclosure

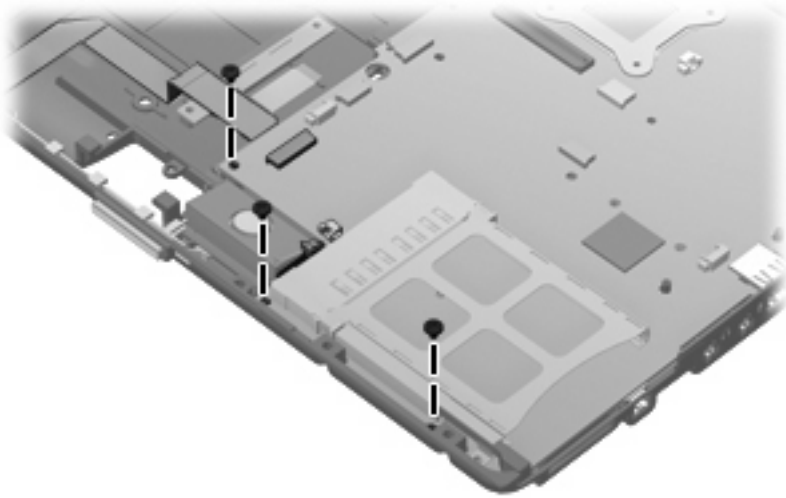

Where used: 3 screws that secure the system board to the base enclosure

Phillips PM2.5×11.0 captive screw

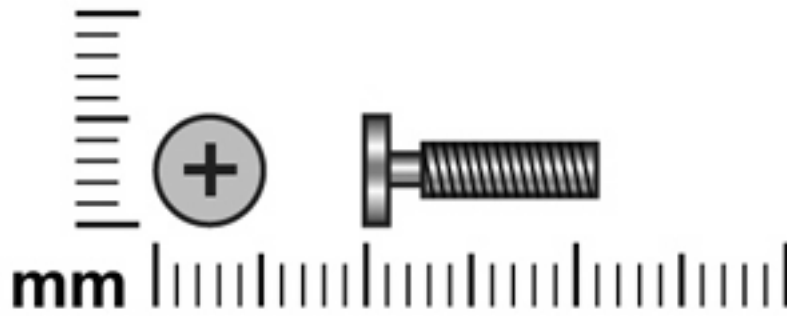

Color	Quantity	Length	Thread	Head diameter
Black	5	11.0 mm	2.5 mm	5.0 mm

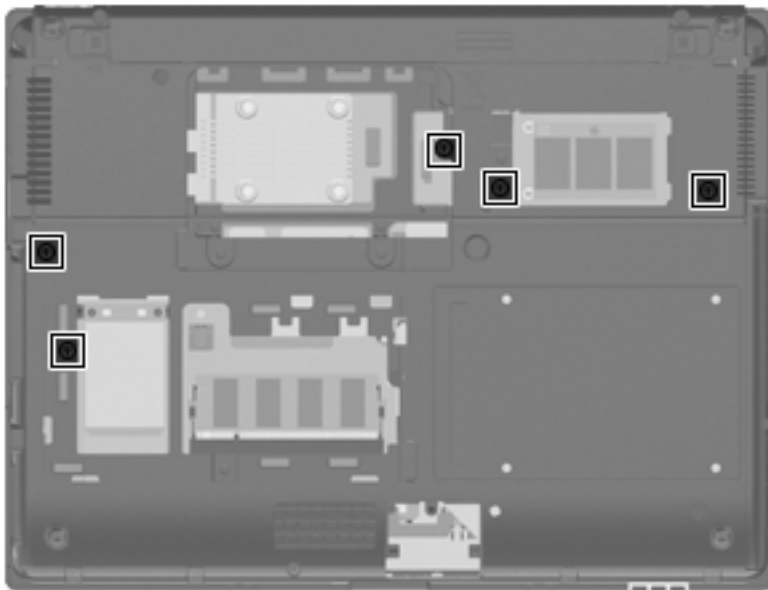

Where used: 5 captive screws that secure the keyboard to the computer (screws are secured by C-clips)

Phillips PM2.5×4.0 screw

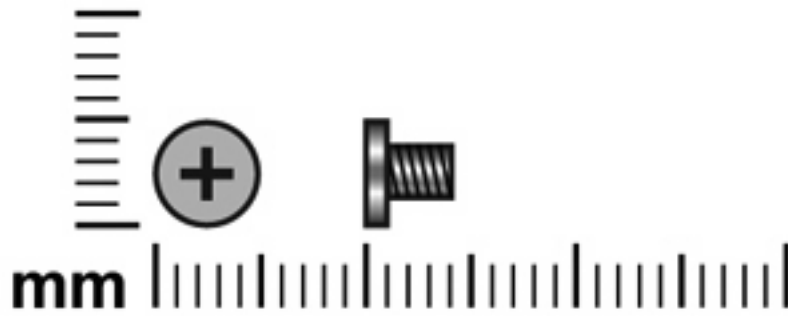

Color	Quantity	Length	Thread	Head diameter
Black	2	4.0 mm	2.5 mm	5.0 mm

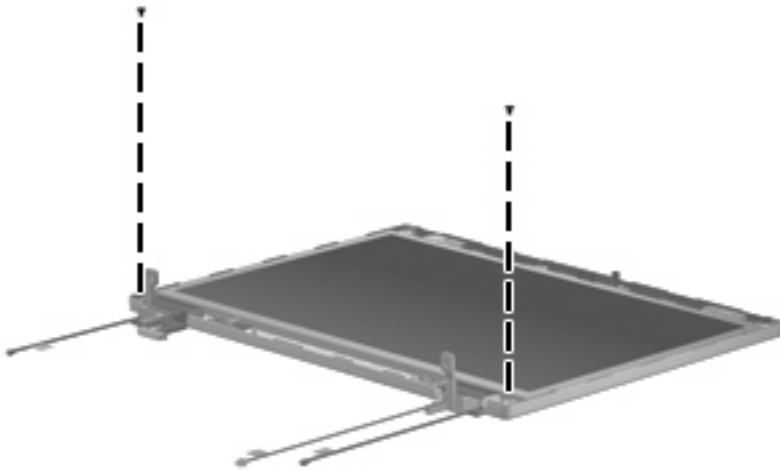

Where used: 2 screws that secure the display panel to the display enclosure

Phillips PM2.0×6.0 screw

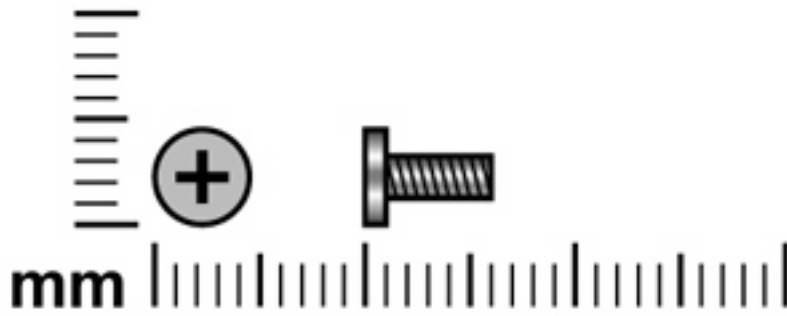

Color	Quantity	Length	Thread	Head diameter
Black	2	6.0 mm	2.0 mm	4.5 mm

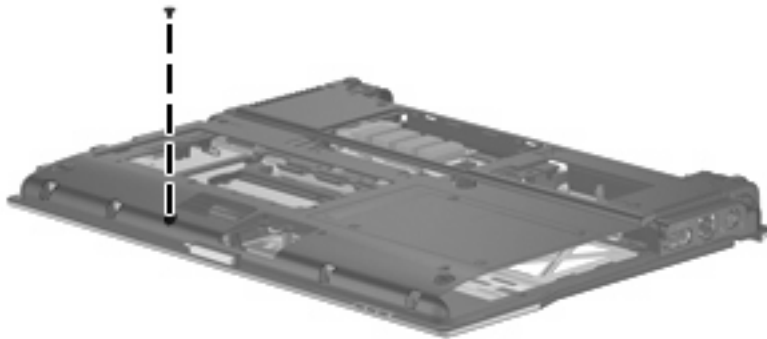

Where used: One screw that secures the top cover to the base enclosure

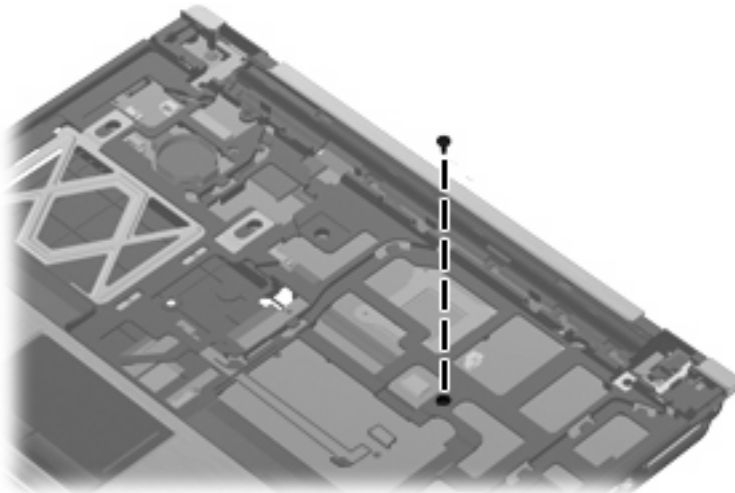

Where used: One screw that secures the top cover to the base enclosure

Phillips PM2.0×5.0 screw

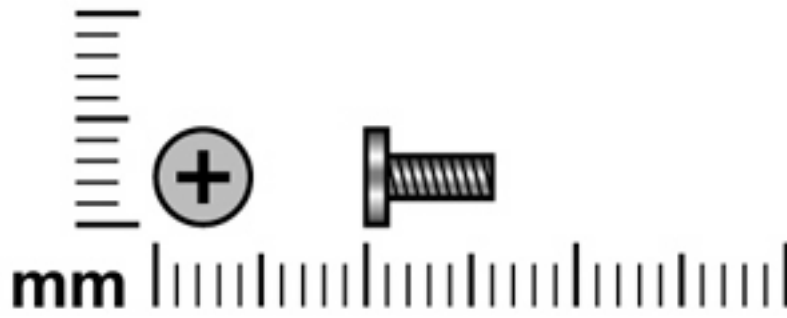

Color	Quantity	Length	Thread	Head diameter
Silver	2	5.0 mm	2.0 mm	4.5 mm

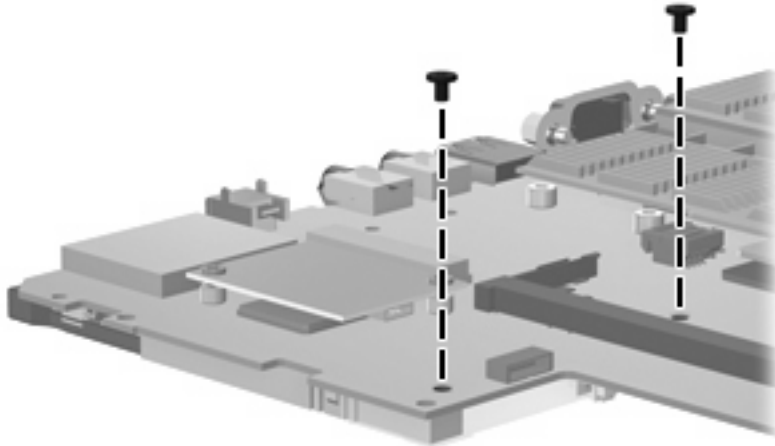

Where used: 2 screws that secure the PC Card assembly to the system board

Torx T8M2.0×10.0 captive screw

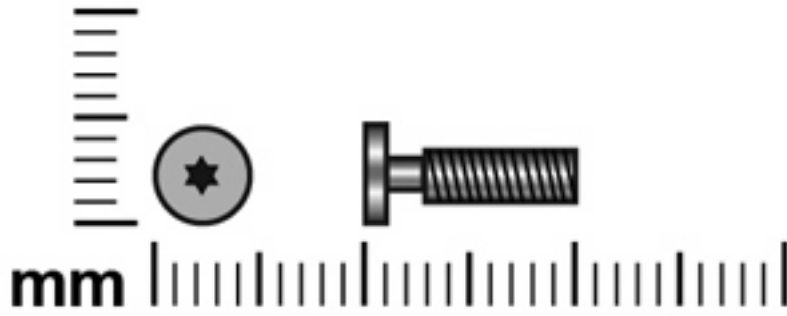

Color	Quantity	Length	Thread	Heat width
Black	4	10.0 mm	2.0 mm	4.5 mm

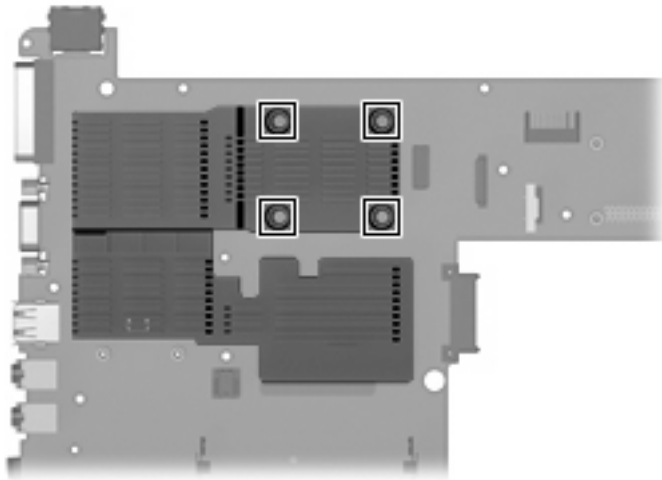

Where used: 4 captive screws that secure the heat sink to the system board (screws are secured by C-clips)

8 Connector pin assignments

Audio-out (headphone)

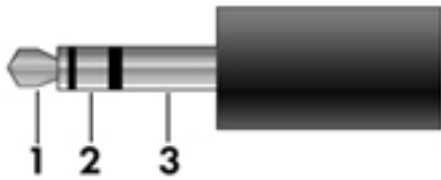

Pin	Signal
1	Audio out, left channel
2	Audio out, right channel
3	Ground

Audio-in (microphone)

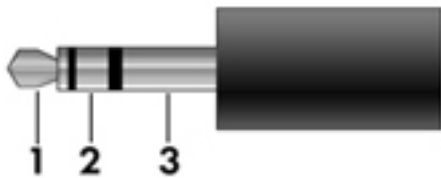

Pin	Signal
1	Audio signal in
2	Audio signal in
3	Ground

External monitor

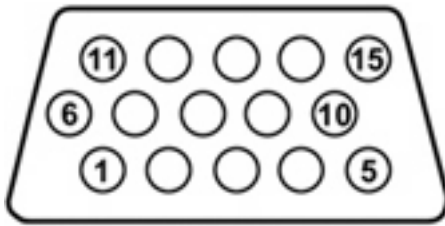

Pin	Signal
1	Red analog
2	Green analog
3	Blue analog
4	Not connected
5	Ground
6	Ground analog
7	Ground analog
8	Ground analog
9	+5 VDC
10	Ground
11	Monitor detect
12	DDC 2B data
13	Horizontal sync
14	Vertical sync
15	DDC 2B clock

RJ-11 (modem)

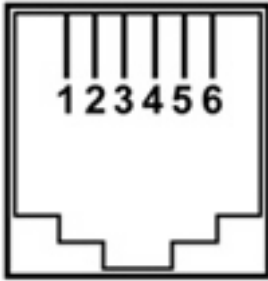

Pin	Signal
1	Unused
2	Tip
3	Ring
4	Unused
5	Unused
6	Unused

RJ-45 (network)

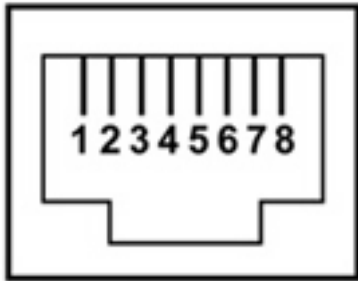

Pin	Signal
1	Transmit +
2	Transmit -
3	Receive +
4	Unused
5	Unused
6	Receive -
7	Unused
8	Unused

Universal Serial Bus

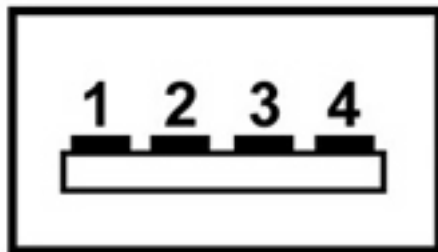

Pin	Signal
1	+5 VDC
2	Data -
3	Data +
4	Ground

9 Power cord set requirements

The wide range input feature of the computer permits it to operate from any line voltage from 100 to 120 volts AC or from 220 to 240 volts AC.

The 3-conductor power cord set included with the computer meets the requirements for use in the country or region where the equipment is purchased.

Power cord sets for use in other countries and regions must meet the requirements of the country or region where the computer is used.

Requirements for all countries and regions

The requirements listed below are applicable to all countries and regions:

- The length of the power cord set must be at least 1.5 m (5.0 ft) and no more than 2.0 m (6.5 ft).
- All power cord sets must be approved by an acceptable accredited agency responsible for evaluation in the country or region where the power cord set will be used.
- The power cord sets must have a minimum current capacity of 10 amps and a nominal voltage rating of 125 or 250 V AC, as required by the power system of each country or region.
- The appliance coupler must meet the mechanical configuration of an EN 60 320/IEC 320 Standard Sheet C13 connector for mating with the appliance inlet on the back of the computer.

Requirements for specific countries and regions

Country/region	Accredited agency	Applicable note number
Australia	EANSW	1
Austria	OVE	1
Belgium	CEBC	1
Canada	CSA	2
Denmark	DEMKO	1
Finland	FIMKO	1
France	UTE	1
Germany	VDE	1
Italy	IMQ	1
Japan	METI	3
Korea	EK	4
The Netherlands	KEMA	1
Norway	NEMKO	1
The People's Republic of China	CCC	5
Sweden	SEMKO	1
Switzerland	SEV	1
Taiwan	BSMI	4
The United Kingdom	BSI	1
The United States	UL	2

1. The flexible cord must be Type HO5VV-F, 3-conductor, 1.0-mm² conductor size. Power cord set fittings (appliance coupler and wall plug) must bear the certification mark of the agency responsible for evaluation in the country or region where it will be used.
2. The flexible cord must be Type SPT-3 or equivalent, No. 18 AWG, 3-conductor. The wall plug must be a two-pole grounding type with a NEMA 5-15P (15 A, 125 V) or NEMA 6-15P (15 A, 250 V) configuration.
3. The appliance coupler, flexible cord, and wall plug must bear a "T" mark and registration number in accordance with the Japanese Dentori Law. The flexible cord must be Type VCT or VCTF, 3-conductor, 1.00-mm² conductor size. The wall plug must be a two-pole grounding type with a Japanese Industrial Standard C8303 (7 A, 125 V) configuration.
4. The flexible cord must be Type RVV, 3-conductor, 0.75-mm² conductor size. Power cord set fittings (appliance coupler and wall plug) must bear the certification mark of the agency responsible for evaluation in the country or region where it will be used.
5. The flexible cord must be Type VCTF, 3-conductor, 0.75-mm² conductor size. Power cord set fittings (appliance coupler and wall plug) must bear the certification mark of the agency responsible for evaluation in the country or region where it will be used.

10 Recycling

Battery

When a battery has reached the end of its useful life, do not dispose of the battery in general household waste. Follow the local laws and regulations in your area for computer battery disposal.

Display

- ⚠ **WARNING!** The backlight contains mercury. Exercise caution when removing and handling the backlight to avoid damaging this component and causing exposure to the mercury.
- ⚠ **CAUTION:** The procedures in this appendix can result in damage to display components. The only components intended for recycling purposes are the liquid crystal display (LCD) panel and the backlight. Careful handling must be exercised when removing these components. When you remove these components, handle them carefully.
- 📄 **NOTE: Materials Disposal.** This HP product contains mercury in the backlight in the display assembly that might require special handling at end-of-life. Disposal of mercury may be regulated because of environmental considerations. For disposal or recycling information, contact your local authorities, or see the Electronic Industries Alliance (EIA) Web site at <http://www.eiae.org>.

This section provides disassembly instructions for the display assembly. The display assembly must be disassembled to gain access to the backlight **(1)** and the liquid crystal display (LCD) panel **(2)**.



- 📄 **NOTE:** The procedures provided in this appendix are general disassembly instructions. Specific details, such as screw sizes, quantities, and locations, and component shapes and sizes, can vary from one computer model to another.

Perform the following steps to disassemble the display assembly:

1. Remove all screw covers (1) and screws (2) that secure the display bezel to the display assembly.

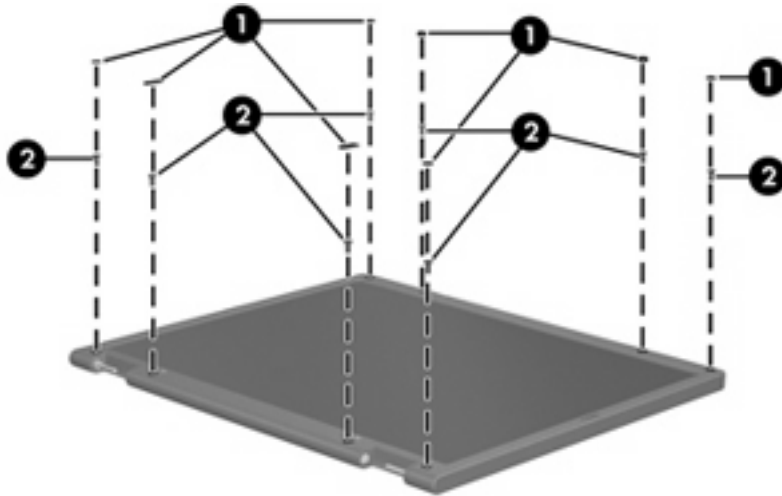

2. Lift up and out on the left and right inside edges (1) and the top and bottom inside edges (2) of the display bezel until the bezel disengages from the display assembly.

3. Remove the display bezel (3).

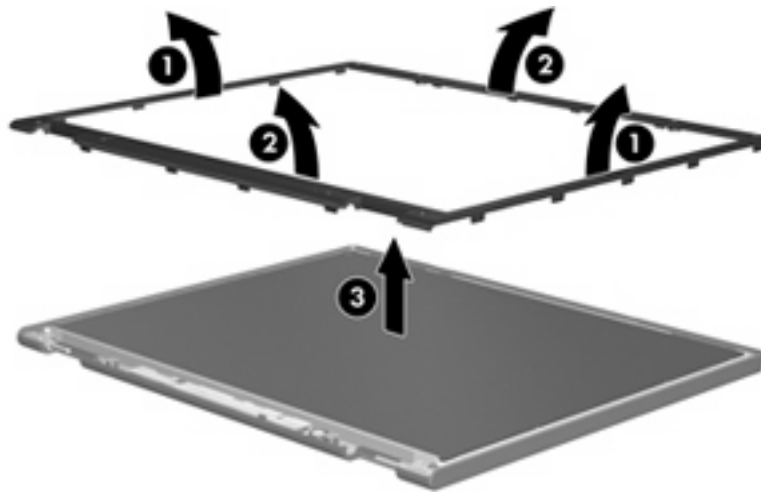

4. Disconnect all display panel cables (1) from the display inverter and remove the inverter (2).

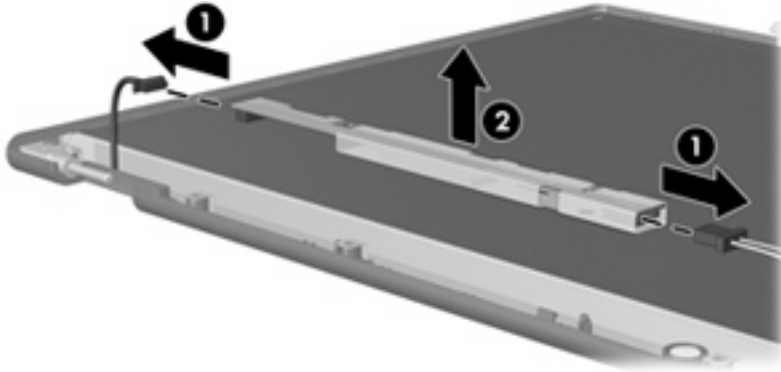

5. Remove all screws (1) that secure the display panel assembly to the display enclosure.
6. Remove the display panel assembly (2) from the display enclosure.

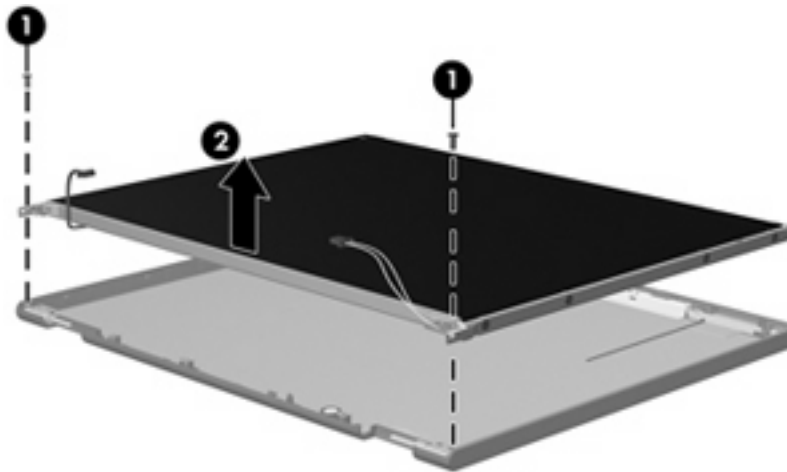

7. Turn the display panel assembly upside down.
8. Remove all screws that secure the display panel frame to the display panel.

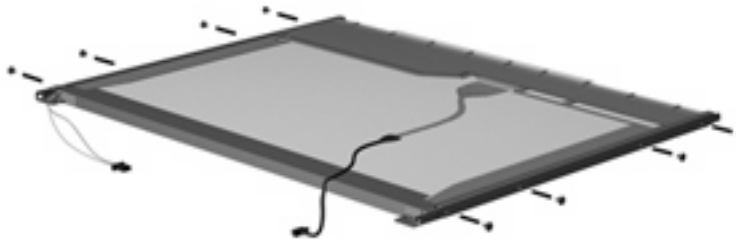

9. Use a sharp-edged tool to cut the tape (1) that secures the sides of the display panel to the display panel frame.

10. Remove the display panel frame (2) from the display panel.

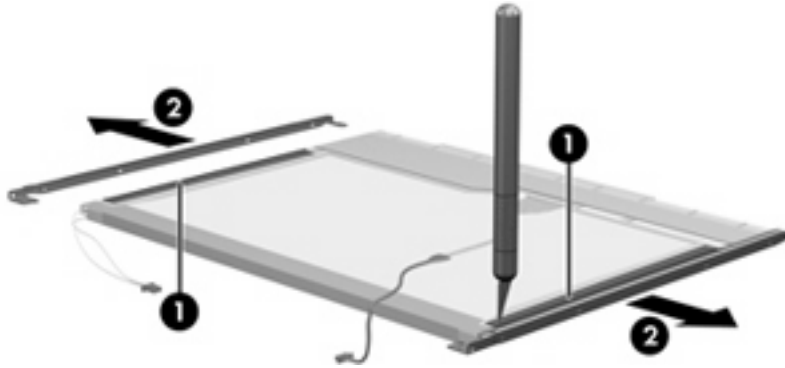

11. Remove the screws (1) that secure the backlight cover to the display panel.
12. Lift the top edge of the backlight cover (2) and swing it outward.

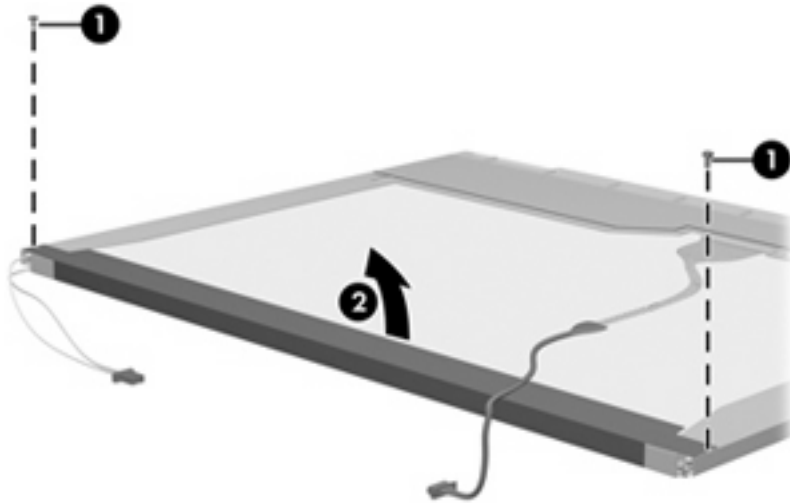

13. Remove the backlight cover.
14. Turn the display panel right-side up.

15. Remove the backlight cables (1) from the clip (2) in the display panel.

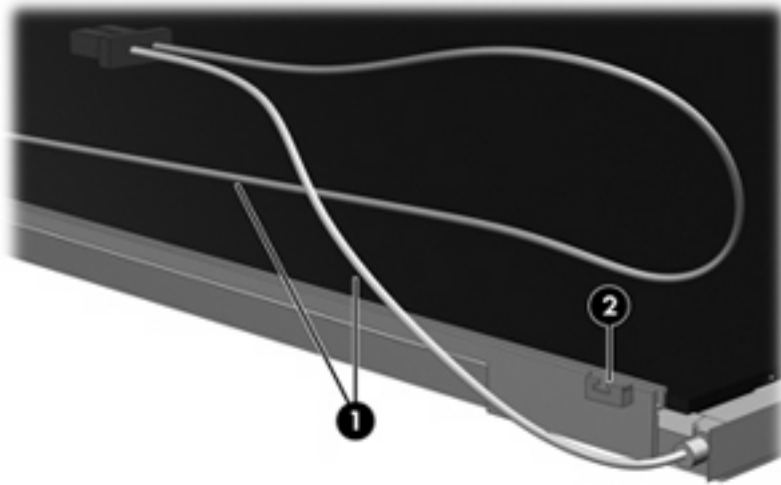

16. Turn the display panel upside down.

⚠ **WARNING!** The backlight contains mercury. Exercise caution when removing and handling the backlight to avoid damaging this component and causing exposure to the mercury.

17. Remove the backlight frame from the display panel.

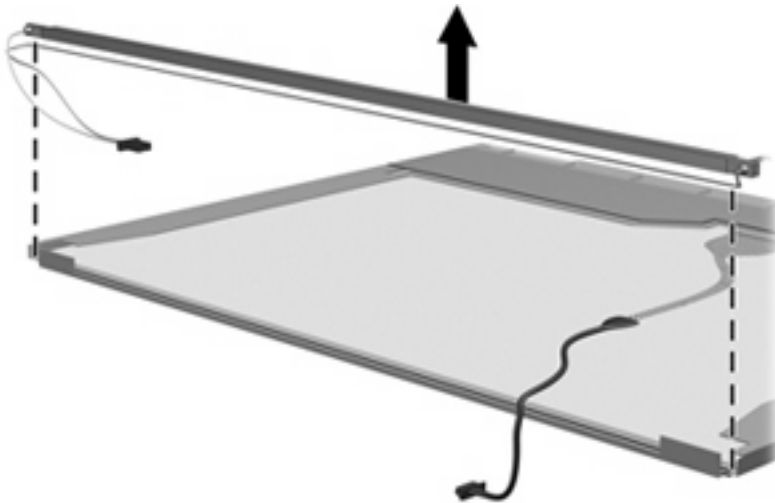

18. Remove the backlight from the backlight frame.

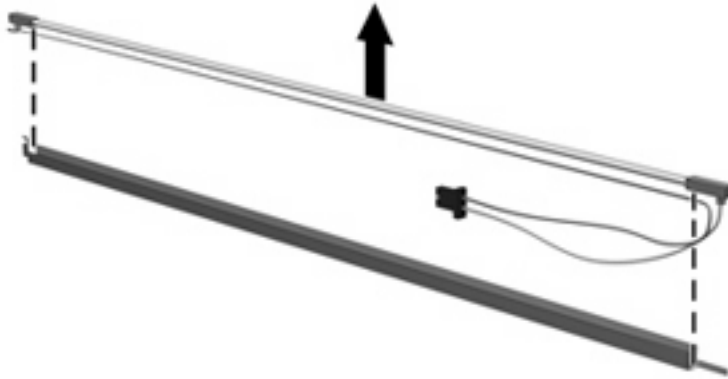

19. Disconnect the display panel cable (1) from the LCD panel.
20. Remove the screws (2) that secure the LCD panel to the display rear panel.
21. Release the LCD panel (3) from the display rear panel.
22. Release the tape (4) that secures the LCD panel to the display rear panel.

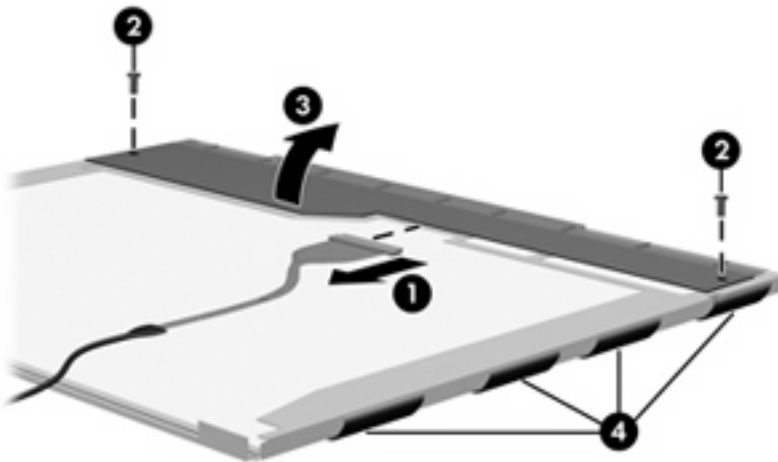

23. Remove the LCD panel.

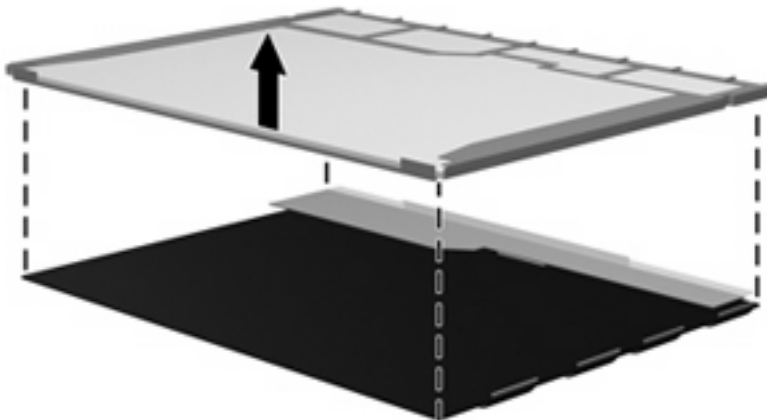

24. Recycle the LCD panel and backlight.

Index

- A**
 - AC adapter, spare part
 - number 20, 21
 - antenna, disconnecting 35
 - audio, product description 2
 - audio-in jack
 - location 11
 - pin assignments 92
 - audio-out jack
 - location 11
 - pin assignments 92
- B**
 - base enclosure, spare part
 - number 18, 21
 - battery
 - removal 30
 - spare part numbers 17, 21, 30
 - battery light 8, 10
 - Bluetooth module compartment
 - cover
 - illustrated 19
 - removal 53
 - boot options 68
 - boot order 68
 - bottom components 14
 - button components 6
 - buttons
 - info 6
 - pointing device buttons 5
 - power 6
 - presentation 6
 - TouchPad 5
 - TouchPad on/off 6
 - volume mute 6
 - wireless 6
- C**
 - Cable Kit
 - contents 20
 - spare part number 18, 20, 21
 - cables, service considerations 24
 - caps lock light 8
 - chipset, product description 1
 - CMOS clearing 28
 - components
 - bottom 14
 - buttons 6
 - display 4
 - front 10
 - keys 7
 - left-side 12
 - lights 8
 - pointing devices 5
 - rear 13
 - right-side 11
 - top 4
 - TouchPad 5
 - computer feet
 - locations 30
 - spare part number 30
 - Computer Setup
 - accessing 65
 - Diagnostics menu 67
 - File menu 67
 - navigating and selecting 66
 - restoring factory settings 66
 - Security menu 67
 - System Configuration menu 68
 - using 66
 - computer specifications 69
 - connectors
 - docking 11
 - connectors, service considerations 24
- D**
 - Diagnostics menu 67
 - diskette drive
 - precautions 24
 - product description 1
 - display assembly
 - removal 47
 - spare part number 16, 22, 47
 - display bezel
 - removal 50
 - spare part number 17, 22, 50
 - display bezel adhesive replacement
 - 49
 - spare part number 17, 22, 49
 - display components
 - illustrated 4
 - recycling 98
 - display enclosure, spare part number 17, 22
 - display hinge
 - removal 51
 - spare part number 17, 22, 51
 - display panel cable
 - removal 51
 - spare part number 17, 22
 - display panel, removal 50
 - display release latch 10
 - display specifications 70
 - docking connector 11
 - drive light 8, 10
 - drives
 - boot order 68
 - preventing damage 24

DVD-ROM Drive
precautions 24
removal 38
spare part number 18, 21,
38
specifications 71

E
electrostatic discharge 25
esc key 7
Ethernet, product description 2
external media cards, product
description 2
external monitor port
location 11
pin assignments 93

F
feet
locations 30
spare part number 30
File menu 67
flash drive
precautions 24
product description 1
removal 36
spare part numbers 18, 22,
36
flash drive compartment cover
illustrated 19
removal 36
fn key 7
front components 10
function keys 7

G
graphics, product description 1
grounding equipment and
methods 27

H
headphone jack
location 11
pin assignments 92
heat sink
removal 63
spare part number 17, 22,
63
hinge
removal 51
spare part number 51

I
I/O address specifications 74
info button 6
interrupt specifications 73

J
jacks
audio-in 11
audio-out 11
headphone 11
microphone 11
modem 12
network 13
RJ-11 12
RJ-45 13

K
key components 7
keyboard
product description 2
removal 40
spare part numbers 17, 22,
40
keypad keys 7
keys
esc 7
fn 7
function 7
keypad 7
Windows applications 7
Windows logo 7

L
language, changing in Computer
Setup 68
LED board
removal 55
spare part number 18, 21,
55
left-side components 12
legacy support, Universal Serial
Bus (USB) 68
light components 8
lights
battery 8, 10
caps lock 8
drive 8, 10
num lock 8
power 8, 10
TouchPad on/off 8

volume mute 9
wireless 8, 10

M
memory check 67
memory map specifications 76
memory module
product description 1
removal 32
spare part number 18, 22,
32
memory module compartment
cover
illustrated 19
removal 32, 35
microphone jack
location 11
pin assignments 92
model name 1
modem jack
location 12
pin assignments 94
modem module
product description 2
removal 61
spare part numbers 17, 21,
61
monitor port
location 11
pin assignments 93

N
navigating in Computer Setup 66
network jack
location 13
pin assignments 95
num lock light 8

O
operating system, product
description 3
optical drive
location 12
precautions 24
product description 1
removal 38
spare part number 18, 21,
38
specifications 71

- P**
- packing guidelines 26
- panels, product description 1
- password clearing 28
- passwords 67
- PC Card assembly
 - removal 59
 - spare part number 17, 22, 59
- PC Card slot 11
- PC Card slot bezel, illustrated 19
- pin assignments
 - audio-in jack 92
 - audio-out jack 92
 - external monitor port 93
 - headphone jack 92
 - microphone jack 92
 - modem jack 94
 - monitor port 93
 - network jack 95
 - RJ-11 94
 - RJ-45 jack 95
 - Universal Serial Bus (USB) port 95
- plastic parts 23
- Plastics Kit
 - contents 19
 - spare part number 17, 19, 22
- pointing device
 - components 5
 - illustrated 5
 - product description 2
- pointing device components
 - pointing stick 5
 - pointing stick buttons 5
 - TouchPad 5
 - TouchPad buttons 5
 - TouchPad scroll zone 5
- pointing stick 5
- pointing stick buttons 5
- ports
 - external monitor 11
 - monitor 11
 - product description 2
 - USB 11, 12
- power button 6
- power connector 12
- power cord
 - set requirements 96
 - spare part number 20, 22
- power light 8, 10
- power requirements, product description 2
- power-on password 67
- presentation button 6
- processor, product description 1
- product description
 - audio 2
 - chipset 1
 - diskette drive 1
 - docking 2
 - Ethernet 2
 - external media cards 2
 - flash drives 1
 - graphics 1
 - keyboard 2
 - memory module 1
 - modem module 2
 - operating system 3
 - optical drives 1
 - panels 1
 - pointing devices 2
 - ports 2
 - power requirements 2
 - processors 1
 - product name 1
 - security 3
 - serviceability 3
 - wireless 2
- product name 1
- R**
- rear components 13
- rear cover
 - illustrated 19
 - removal 41
- removal/replacement
 - preliminaries 23
 - procedures 29
- restoring Computer Setup factory settings 66
- right-side components 11
- RJ-11 jack
 - location 12
 - pin assignments 94
- RJ-45 jack
 - location 13
 - pin assignments 95
- RTC battery
 - removal 46
 - spare part number 17, 21, 46
- Rubber Kit, spare part number 18, 22
- S**
- Screw Kit
 - contents 77
 - spare part number 20, 22
- screw listing 77
- SD Card Reader 11
- security cable slot 13
- Security menu 67
- security, product description 3
- selecting in Computer Setup 66
- serial number 15, 29
- service considerations 23
- serviceability, product description 3
- smart card reader, spare part number 18, 22
- speaker
 - removal 56
 - spare part number 18, 22, 56
- specifications
 - computer 69
 - display 70
 - DVD-ROM Drive 71
 - I/O addresses 74
 - interrupts 73
 - memory map 76
 - optical drive 71
 - system DMA 72
- static-shielding materials 27
- stringent security 67
- switch cover
 - removal 40
 - spare part number 17, 21, 40
- system board
 - removal 57
 - spare part number 17, 21, 57
- System Configuration menu 68

- system DMA 72
- system information 67
- system memory map 76

T

- thermal material, replacement 64
- tools required 23
- top components 4
- top cover
 - removal 52
 - spare part number 17, 22, 52
- TouchPad 5
- TouchPad buttons 5
- TouchPad components 5
- TouchPad on/off button 6
- TouchPad on/off light 8
- TouchPad scroll zone 5
- transporting guidelines 26

U

- Universal Serial Bus (USB) legacy support 68
- unknown password 28
- USB board
 - removal 44
 - spare part number 18, 22, 44
- USB port
 - location 11, 12
 - pin assignments 95

V

- vent 11, 12
- volume mute button 6
- volume mute light 9

W

- Windows applications key 7
- Windows logo key 7
- wireless antenna,
 - disconnecting 35
- wireless button 6
- wireless light 8, 10
- wireless, product description 2
- WLAN module
 - removal 34
 - spare part numbers 18, 21, 34
- workstation guidelines 26

